



FIBERGLASS UNDERGROUND STORAGE TANKS

Water & Wastewater

MUNICIPAL | INDUSTRIAL | COMMERCIAL



Fiberglass Tank SOLUTIONS

“BUILT FOR THE LIFE OF THE TANK”

MARKETS WE SERVE

Municipal | Industrial | Commercial

Fiberglass Tank Solutions builds underground storage tanks for the municipal, industrial, and commercial markets. Our underground tanks are built to **exceed industry standards**, while providing more **custom features**. FTS delivers tanks to the markets we serve with **realistic delivery dates**, at **competitive prices**.

TANK APPLICATIONS WE BUILD

- **100% WATERTIGHT • LIGHTWEIGHT • CORROSION RESISTANT**

WHY WORK WITH FIBERGLASS TANK SOLUTIONS

There is a reason why the word **“Solutions”** is in our name. Every underground tank that we build has it’s own set of unique conditions, features, and specifications to meet the applications. FTS builds **“Custom”** underground tanks with market specific accesories, piping, and in-house kit up to add value and performance to the tanks function in each market we serve.

From your initial contact with our knowledgable sales team, to manufacturing by our experienced workforce, through the final tank delivery, we promise that as our **customer**, you will get the **personal attention required** to provide your project’s successful underground tank installation.

- **Decentralized / On-site Wastewater**
- **Municipal Wastewater**
- **Fire Suppression**
- **Rainwater Harvesting**
- **Potable Water**
- **Hazardous Liquid Collection**
- **Grease / Oil / Sand Interceptors**
- **Oil / Water Seperators**

- **Knowlegable Inside Sales Staff**
- **Conclusive Submittals / CAD / FEA Analysis**
- **Quality Management Plan**
- **Certified Mechanical Engineers**
- **State of the Art Tooling & Modern Facility**

- **4' - 12' Diameter**
- **Single Tank Up To 50,000 Gallons**
- **Single & Double Wall Designs**
- **Deep Bury**
- **H-20 Load Rated**

PREPACKAGING PAYS

Unlike concrete or steel tanks, fiberglass is lightweight and extremely strong, allowing us to build and prepackage the system in a quality-controlled manufacturing facility. Prepackaging also limits labor cost and confined space entry risk in the field. The result is finished products that are unmatched in quality, fit, and performance when compared to any other similar products in the industry. From our sales team to our engineers, laminators, fitters, and welders, each segment of our workforce is experienced in providing the most custom features to our fiberglass above ground tanks, underground tanks, and prepackaged large-diameter lift stations.

- A.** Engineered Anti-Floatation System
- B.** Internal Piping & Equipment Kit-Up
- C.** Flow Through & Watertight Baffles
- D.** Multiple Access Opening, Riser, and Manway Options
- E.** Prepackaged Pump Systems
- F.** Pump Platforms

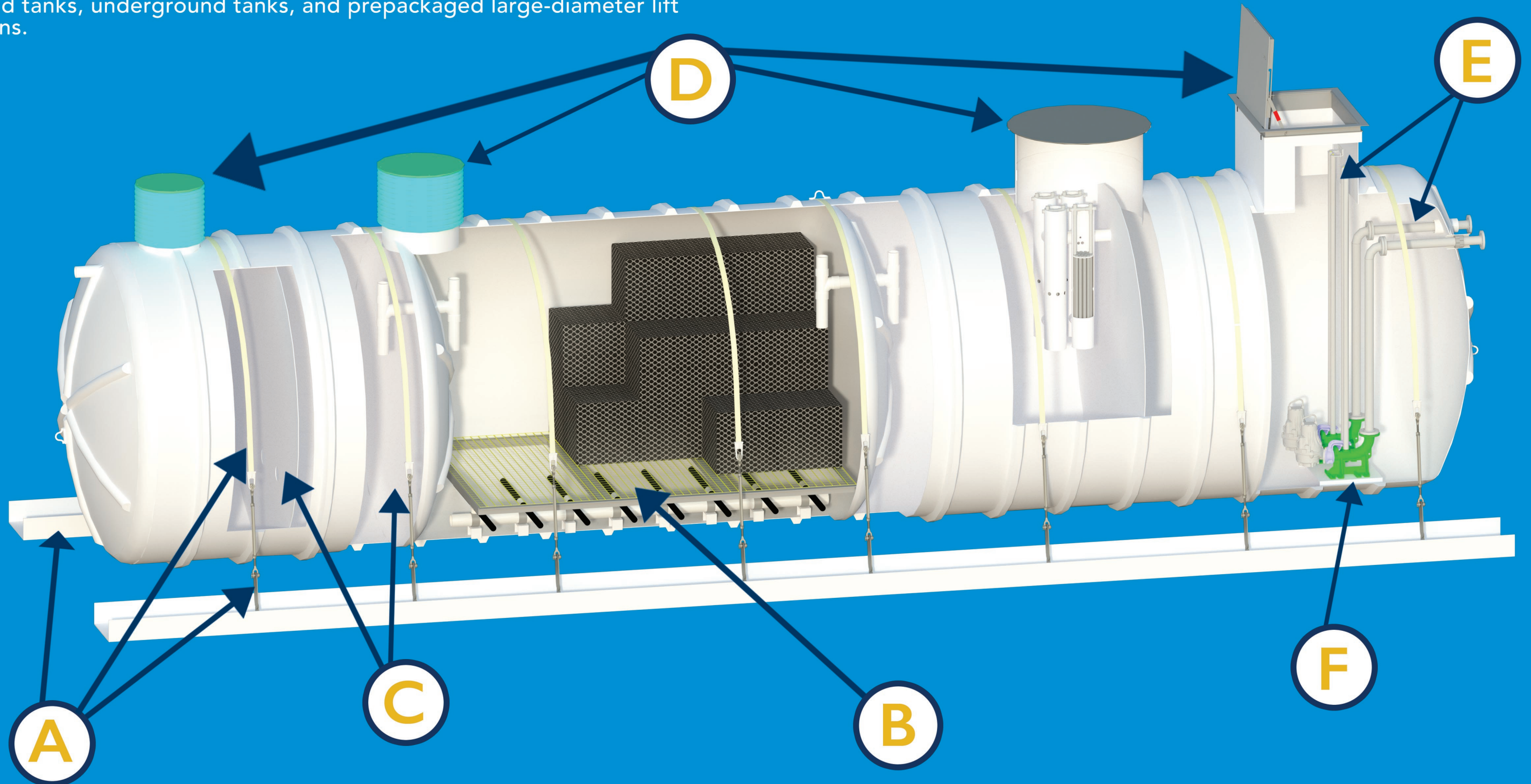

- Hinged & Lockable Risers
- Manways & Extensions
- Flanges / Nozzles / Sleeves
- H-20 Steel & C.I. Covers
- Media Platforms & Grating
- Containment Sumps 42"- 48"
- Pump Platforms
- Flex Connections
- Straps / Turnbuckles
- Interior Piping
- Baffle Walls
- Pump Vaults

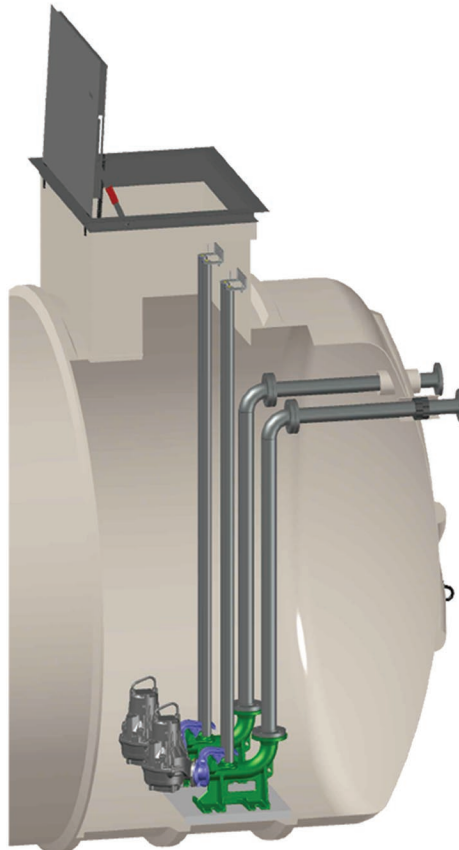
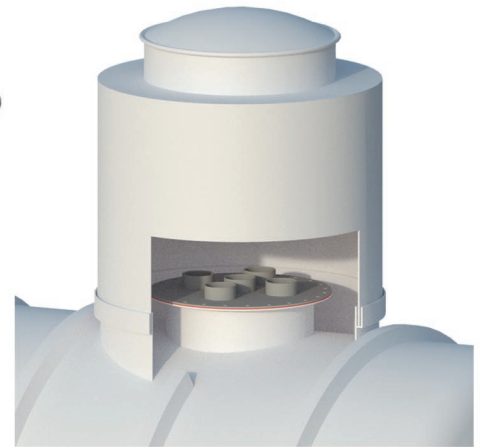
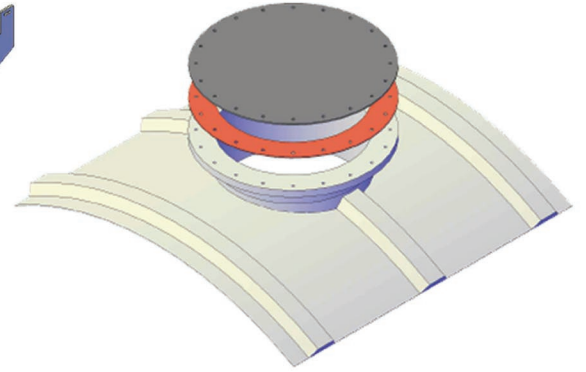
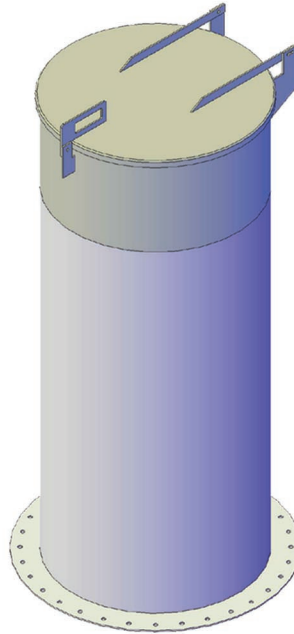

Engineered Fiberglass Deadman System (EFD)

Our engineered fiberglass deadman system includes structural fiberglass deadmen, along with the proper turnbuckles and straps for each tank size we build.

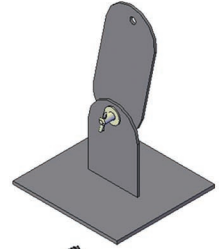
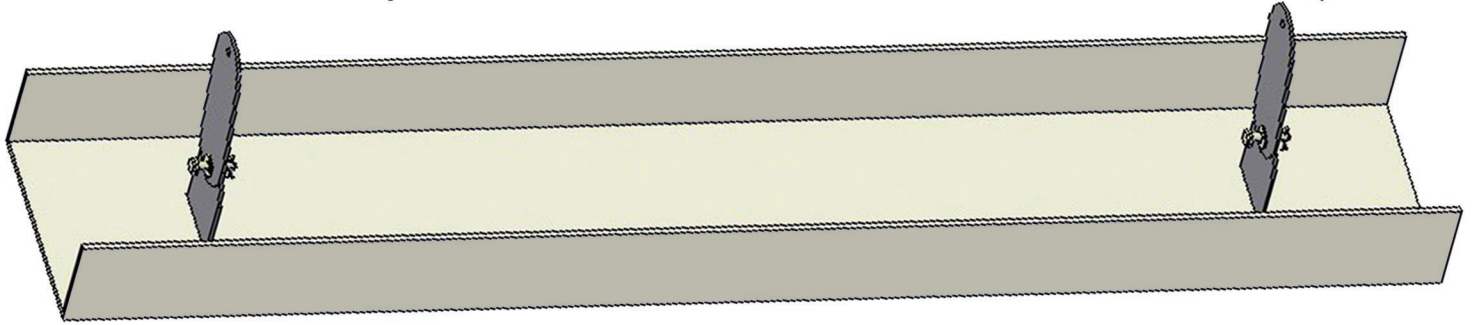

TankAnchor® – The “Geo-Composite Option”

Our TankAnchor® system provides an engineered geo-composite that utilizes the soil loads to offset buoyancy. The TankAnchor® allows for shallower bury applications with higher safety factors, as compared to conventional deadmen systems. TankAnchor® can be utilized for single or double tank installations in open cut trench excavations utilizing a 34°, 45°, or 54° angle.

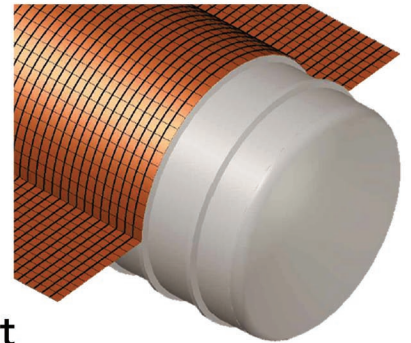

Both anchoring systems are fully supported with engineering buoyancy calculations, utilizing industry accepted safety factors.

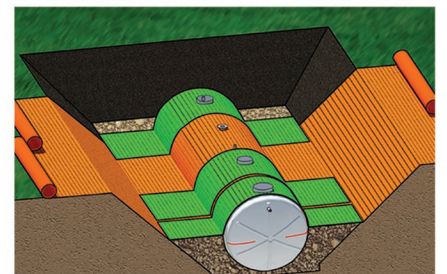

OTHER PRODUCTS WE BUILD

- Fiberglass Lift Stations
- Above Ground Tanks
- OEM Manufacturing



(573) 317-9620

www.fgtsolutions.com



147 Opportunity Rd.

Camdenton, MO 65020

