



Table of Contents

Pre-Construction	1.0 Introduction.....	3
	1.1 Intended Application & Units of Measure	4
	1.2 General Equipment List & Site Safety Considerations	5
	2.1 Burial Depth & Clearances	6
	2.1 Burial Depth & Nearby Structures.....	7
	2.1 Burial Depth & Clearances Summary	8
	2.2 Bedding, Backfill & Geotextile	9
	2.2 Secondary Backfill & Geotextile.....	10
	2.3 Lifting & Handling Tanks	11
	2.4 Anchoring Tanks	12
2.4 Anchoring Hardware.....	13	
2.5 Ballasting Tanks	14	
2.6 Deflection Measurements	15	
2.7 Tank Testing.....	16	
2.8 Troubleshooting DW Tanks	17	
2.9 Pre-Construction Checklist.....	18	
Installation	3.0 Lifting Tank into Excavation	19
	3.0.1 FTS Lifting Slings.....	20
	3.0.2 FTS Lifting Slings – Visual Steps	21
	3.1 Installing Tanks	22
	3.1.2 Backfilling The Tank	23
	3.2 & 3.3 Venting Tanks & (3.3) Piping.....	24
	3.4 Containment Collars	25
	3.5 Interstitial Monitoring	26
	3.6 & 3.7 Confined Entry Requirements & (3.7) Filling Tanks	27
	3.8 Installing Containment Sumps & Access Risers	28
Resources	Glossary.....	29
	Appendix A: UST Chart	30
	Appendix A: UST Chart	31
	Appendix AA: Fuel Chart	32
	Appendix B: Primary Backfill	33
	Appendix C: Secondary Backfill	34
	Appendix C: Secondary Backfill Charts.....	35
	FTS Installation Checklist	36
	FTS Installation Checklist	37
	FTS Installation Checklist	38



Seeing this Camera icon means you need to take a picture for the FTS Checklist.

NOTE: This Table of Contents section is also a digital menu that is linked to each section within this document. When viewed digitally, you can click these links to jump to that section in this IMOG. You can also click the “Back to Table of Contents” button on the top of each page to return to this menu.

KEY NOTIFICATIONS!

SAFETY

The following definitions will serve as a guide when reading this manual:

▲ WARNING Indicates a potentially hazardous situation, which, if not avoided, could result in death or serious injury.

▲ CAUTION Indicates a potentially hazardous situation, which, if not avoided, could result in minor or moderate injury.

NOTICE Indicates information considered important but not hazard related. Failure to heed this notice could result in property damage or tank failure.

It is the responsibility of the owner, installer, and operator to:

- Follow all instructions in this document.
- Comply with federal, state, and local safety regulations related to underground storage tank installation and operations.
- No part of this document should be interpreted in a way that risks health, safety, property, or the environment.

Follow OSHA regulations for excavations. Collapse of excavation walls could result in death or serious injury.

- Working in and around excavations is dangerous. Prior to beginning work at the site, the installer must follow any governmental or other codes and/or regulations applicable to excavations.
- Careless or reckless equipment operation can cause death, injury, or damage.
- Government regulations override our IMOG requirements.
- Follow IMOG procedures for safe, successful, & proper underground storage tank installation.

Note: Record the required information for each tank installed on the Tank Installation Checklist. Additional copies are available at:

www.fgtsolutions.com

[Download the PDF HERE](#)

1.0 READ THIS ENTIRE DOCUMENT BEFORE INSTALLATION!

- Read all instructions, supplemental documents, and guidelines before installing.
- Non-compliance voids the warranty and risks injury, damage, or tank failure.
- The Installation Manual and Operating Guidelines (this document) will be referred to as the “IMOG”, Fiberglass Tank Solutions (FTS) will be referred to as “FTS”, & “FTS Checklist” as the FTS Installation Checklist.

1.0.1. Installer: Read and understand the IMOG before tank installation. Deliver the IMOG and FTS checklist to the owner after installation.

1.0.2. Owner: Keep the IMOG, FTS Checklist, photographs, documentation and warranty for reference.

- Our (FTS) representative's presence during any installation does not shift responsibility for proper installation to the manufacturer.
- FTS' limited warranty applies only to tanks installed as instructed.
- Federal, state, and local codes take precedence over FTS instructions.
- Contact relevant authorities (health, fire, building, environmental) for additional info.
- FTS must authorize any Installation deviations from these instructions in writing.

1.0.3. Introduction

- FTS provides this IMOG in multiple formats: a physical copy delivered with all tank shipments, one copy attached to the tank, and an electronic version available on our website (<https://fgtsolutions.com>).
- **NOTE:** The digital PDF or website version of this IMOG allows for each section to be jumped to, linked to, or opened and saved as separate PDF files for printing purposes and sharing digitally.

1.0.4 Goals and Objectives of this Document

- This document is intended to provide a comprehensive and user-friendly document that guides tank owners and installers through the installation process. Most sections of the manual will be available as a separate document on our website.
- All tanks require items such as lifting and handling instructions and an understanding of the required backfill material and testing requirements. The use of an anchoring system or other accessories sold with the tank are job-specific and can be referenced as necessary for the project.

1.0.5. The FTS Checklist can be found on the last 3 pages of this IMOG. (Or Here: [FTS Checklist](#))

- Use this document, take detailed pictures, and fill out the FTS Checklist throughout the installation process.

Units Conversion Examples

Length Conversion Examples	
Inches (in)	Millimeters (mm)
1	25.4
6	152.4
8	203.2
12	304.8
18	457.2
24	609.6
30	762
36	914.4
42	1,066.8
48	1,219.2

Pressure Conversion Examples	
Pounds per square inch (psig)	Kilopascals (kPa)
1	6.9
3	20.7
5	34.5
6	41.4
10	69.0
15	103.4
25	172.4

Weight Conversion Examples	
Pounds (lbs)	Kilograms (kg)
1	0.45
10	4.54
100	45.4
10,000	4,536

Volume Conversion Examples	
US Gallons (gal)	Liters (L)
1	3.79
10	37.85
100	378.5
10,000	37,850

1.1. Intended Application

1.1.1 Tank Storage and Warranty

- Each tank is designed to store only the products listed in its limited warranty.
- Storing unapproved products not listed in the warranty will void the warranty and may cause tank failure or property damage.
- The temperature of stored products must not exceed the limits specified in the limited warranty.

1.1.2. Installation and Maintenance

- Proper installation and maintenance, as outlined in the Installation Manual, are essential for safe use.
- Refer to any supplemental materials mentioned in the Introduction for additional guidance.
- Verify that the correct backfill material is used during installation.
- Ensure burial depth, tank spacing, and soil conditions meet necessary requirements.
- Nearby structures must not apply downward pressure on the tanks.

1.1.3. Compliance and Regulations

- The installed tank must comply with NFPA (30, 30A, and 31) and all applicable Federal, State, Local, or Provincial codes and regulations throughout its lifetime.
- If installing additional tanks near existing ones, follow the instructions in "Installing Tanks at Existing Locations."

1.1.4. FTS Tanks are Built to Comply

- FTS petroleum tanks are designed for a maximum burial depth of 7 feet.
- FTS water tanks are designed for a maximum burial depth of 7 feet.
- FTS water tanks can be ordered for deeper burial depths if needed.

1.1.5. Maximum Test Pressure

- Tanks have been designed at a maximum test pressure of 5.0 psig (3 psig for tanks larger than 10 feet in diameter).

1.1.6. Annular Space & Interstitial Ratings

- Tanks have been designed with the annular space full of a maximum 1.4 specific gravity fluid, or to be dry monitored at atmospheric pressure.
- Maximum rated dry interstitial pressure: 5 psig.
- Maximum rated dry interstitial vacuum: 5 psig.

1.1.7. Unit Conversions

- The following unit conversions are helpful when converting from US Standard units to Metric (also refer to the examples on the left):

LENGTH	WEIGHT
mm = millimeters	kg = kilogram
1 in. = 25.4 mm	1lb = 0.45 kg
PRESSURE	CAPACITY
kPa = kilopascals	L = liters
1 psi = 6.9 kPa	1 gal = 3.79 L

KEY NOTIFICATIONS!

⚠ WARNING

Consult OSHA's regulations, and/or applicable federal, state and municipal safety codes and operational regulations, whichever are relevant. Collapse of excavation walls could result in death or serious injury.

NOTICE

FTS does not require onsite pressure testing if the tank meets the "as received" requirements in Section 2.7, but some owners or regulators might require pressure testing.

NOTICE

If onsite testing is required, the installer should be prepared to build pressure-test manifold(s) per the specifications in Section 2.7 on Figure 2-11.

1.2.0. General Equipment List & Site Safety Considerations

1.2.1. The following list is to be used as a guide for equipment recommended for tank installation:

- Excavation equipment capable of safely producing a level-bottom hole and placing backfill material at any point in the excavation.
- Suitable lifting equipment capable of lifting and placing the tanks and associated tank anchors – See [Appendix A](#).
- Spirit level ("bubble level").
- Transit or grade level.
- 50-foot tape measure.
- Non-metallic tamping rod(s).
- Pipe wrenches and appropriate pipe joint compound.
- A test manifold for each pressure-testable tank or compartment (reference **Figure 2-11 in Section 2.7**).
- Permanent plugs.
- Source of pressurized air capable of 5 psig or inert gas.
- Soap and water solution (during freezing conditions, a suitable solution such as windshield washer fluid may be added to the soap and water mixture).
- Soft cloth, brush or hand-held pneumatic sprayer.
- Hand shovel.
- Lifting sling(s).
- Soil compacting equipment (if necessary).
- De-watering pumps.
- Spray paint (useful for placing tanks and deadmen in the excavation).

1.2.2. At the time of installation, the installing contractor must take all necessary precautions in or near a tank excavation.

1.2.2.1. These onsite precautions should include but are not limited to the following:

- All personnel onsite needs to use appropriate personal protection equipment (PPE). **Refer to OSHA & STATE regulations.**
- Locate and protect any utility installations near the excavation before opening the excavation.
- Secure the walls of the excavation.
- Take appropriate precautions to protect against exposure to hazardous vapors from the excavation.
- Avoid hazards associated with water accumulation in the excavation.
- Erect barricades (such as orange netting fence), to prevent unauthorized vehicle or pedestrian traffic.
- Inspect, as required, the excavation and surrounding area during the entire installation process. See [FTS Checklist](#).
- Berm and direct stormwater run-off from the excavation site.

KEY NOTIFICATIONS!

Follow OSHA (or relevant government) regulations to prevent excavation collapse, which could cause death or injury.

Ensure the excavation is secure, free of hazards, and properly protected from unintended water accumulation and unauthorized access. If site specific conditions fall outside the parameters, contact the engineer.

Failure to follow the warnings below could result in damage to the tank, property damage, serious personal injury, and/or death.

⚠ Caution: It is the responsibility of the project engineer to consult a local foundation expert for guidance when unstable soil conditions are found.

Unstable Soils Installations:

Note: These conditions affect excavation size and may require extra stabilizing materials under the tank and/ or off the sides of the tank.

- Ensure at least half the tank's diameter of space between the tank and the excavation wall to improve lateral tank support, with or without the use of shoring. **See Figure 2-3.**
- If the excavation bottom is unstable, stabilization measures are extra bedding material under the tank (more than the minimum required 12-inches), or a reinforced concrete slab may be required under the tank as determined by the project engineer.
- If using a slab under the tank, place a minimum 12-inch bedding layer on top of the slab; do not position the tank directly on the slab.
- Geotextile fabric is required for areas with unstable soil. See the "Geotextile Specifications" in **Section 2.2.4.**

2.1. Burial Depth and Clearances

- Site and service conditions will affect burial depth and clearances.
- Consult the engineer of record familiar with the site for proper tank placement and assessment of the soil types encountered.
- Accommodations may be needed to account for nearby structures and anchoring systems.

2.1.1. Considerations For All Sites

2.1.1.1. The standard tank design is for a maximum depth of 7 feet, from top of tank to finished grade.

- Deeper bury tank installations require custom quote, design & manufacturing and are only approved on a case-by-case basis before tank construction. Contact FTS.

2.1.1.2. All tanks must be bedded with at least 12" Primary Backfill material under the tank (referred to as "bedding material"). **See Figure 2-5.**

2.1.1.3. Burial depth and tank spacing can vary based on the following:

- Unstable soils in the area where the tank is to be installed.
- Tank size, quantity, and layout of tanks (i.e. end to end or side by side).
- Presence or absence of traffic over the tank at finished install.
- Presence or absence of water in the excavation.
- Presence or absence of an anchoring system (deadmen or anchor slab) for the project.
- Proximity to nearby existing or future structures.

2.1.2. Unstable Soils

2.1.2.1. Generally, unstable soils have low:

- Cohesive strength (less than 750 lbs/sq. ft., using a compression test).
- Bearing capacity (less than 3,500 lbs/sq. ft.).

2.1.2.2. Some examples of unstable soils include peat, quicksand, muck, fill material, soft or highly expansive clays, areas with underground streams, or areas with highly disturbed soil.

2.1.2.3. Unstable soil conditions will affect tank clearances. See the "Key Notifications" section (left side of this page) and **Table 2-3** for additional information.

NOTE: Geotextile must be used in unstable soil conditions. **See Figure 2-5.**

2.1.3. Tank Clearances

2.1.3.1. Minimum clearance between tanks (including tank ends) is 18". (Note that this is 24" in Canada.). See **Table 2-3.**

2.1.3.2. For multiple tank installations, tanks can be installed side-by-side or end-to-end.

- Spacing between the sides of tanks need to be increased to accommodate an anti-buoyancy tank anchoring system (deadman). Refer to **Table 2-2 & Figure 2-2**

2.1.4. Excavation Depth

2.1.4.1. The site plans need to include at least 12" backfill/bedding material under the tank. Including 12" bedding if an anchor slab is used under the tank. The tank cannot be placed directly on an anchor slab.

2.1.4.2. Tanks are not designed to support the downward forces exerted by a buildings footing. Refer to the "Nearby Structures" **Section 2.1.6 & Figure 2-1.**

KEY NOTIFICATIONS!

⚠ CAUTION

In both traffic and nontraffic installations, no truck or equipment loads are allowed over the tank until the backfill is at least at the depth of cover specified in **Table 2-1 & 2-2**. Failure to follow this caution could result in minor or moderate injury, and/or damage to the tank.

NOTE: All measurements are measured from top of tank to finished grade.

NOTE: The maximum burial depth for a standard tank is 7 feet from top of tank to finish grade. Contact your FTS sales manager for information and options regarding bury depths greater than 7ft.

2.1.5. Minimum Burial Depth Requirements

- See detailed information on **Table 2-2. & Figure 2-2 (on next page)**
- For fuel tanks with no traffic, the required minimum coverage includes either 24 inches of backfill, 12 inches of backfill with 4 inches of reinforced concrete, or 12 inches of backfill with 6 inches of asphalt.
- Non-fuel tanks in areas without traffic follow the same guidelines, requiring either 24 inches of backfill, 12 inches of backfill with 4 inches of reinforced concrete, or 12 inches of backfill with 6 inches of asphalt.
- If a surface pad is used, surface pads must extend a minimum of 12 inches beyond the tank in all directions.
- In areas subject to traffic (H-20 or HS-20) loading, the minimum coverage must consist of either 36 inches of backfill, 18 inches of backfill with 6 inches of reinforced concrete, or 8 inches of asphalt.

2.1.6. Nearby Structures (Figure 2-1)

- When selecting a tank site, care must be taken to avoid undermining the foundations of existing structures or new buildings to be constructed.
- Ensure that downward forces from loads carried by the foundations and supports of nearby structures (constructed before or after tank installation) are not transmitted to the tanks.
- Keep tanks outside a 45-degree line ("Shadow") from nearby foundations to prevent structural impact. See **Figure 2-1**.
- Typically, the way to check the placement of the tank in relationship to a nearby structure is to do the following:
 - **Step 1** - Determine the depth of burial needed for the tank.
 - **Step 2** - Locate the footing of the structure to be considered.
 - **Step 3** - Determine the line that would fall into the ground from a 45-degree angle drawn downward from the corner(s) of the footing of the foundation that is closest to the tank.
 - **Step 4** - The tank must not fall within the "shadow" of the 45-degree-angle line drawn from the foundation's footing. If so, see alternatives:
 - **Alternative A** - Move tank away from building.
 - **Alternative B** - Deepen buildings footing.

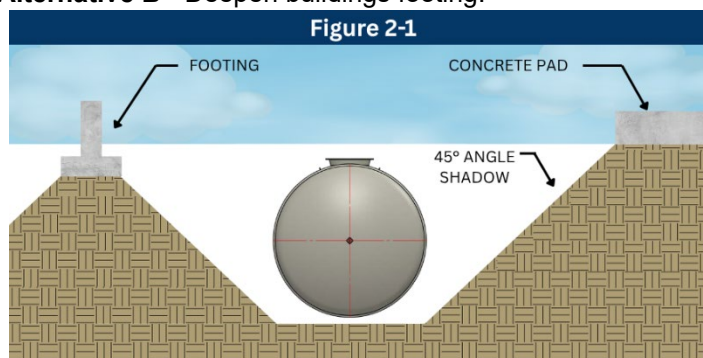

2.1.7. Other Excavation Considerations

- Prevent stormwater from entering the tank and/or the tank excavation.
- Ensure traffic loads are not transmitted directly to tanks or tank accessories, during installation or service.
- If the water table is very high and cannot be controlled, refer to the ballasting instructions section of this document. See **Section 2.5**.

⚠ CAUTION

In both traffic and nontraffic installations, no truck or equipment loads are allowed over the tank until the backfill is at least at the depth of cover specified in Table 2-2. Failure to follow this caution could result in minor or moderate injury, and/or damage to the tank.

Table 2-2: Minimum Burial Depth Summary

Tank and Install Type	Minimum Burial Depth Requirement (From Top of Tank to Grade)
Fuel Tanks - In areas without traffic	24" primary backfill, or 12" primary backfill + 4" reinforced concrete (RCC), or 12" primary backfill + 6" asphalt
All other tanks - In areas without traffic	12" primary backfill
All Tanks - In areas with traffic	36" primary backfill, or 18" primary backfill + 6" reinforced concrete (RCC), or 18" primary backfill + 8" asphalt

Table 2-2

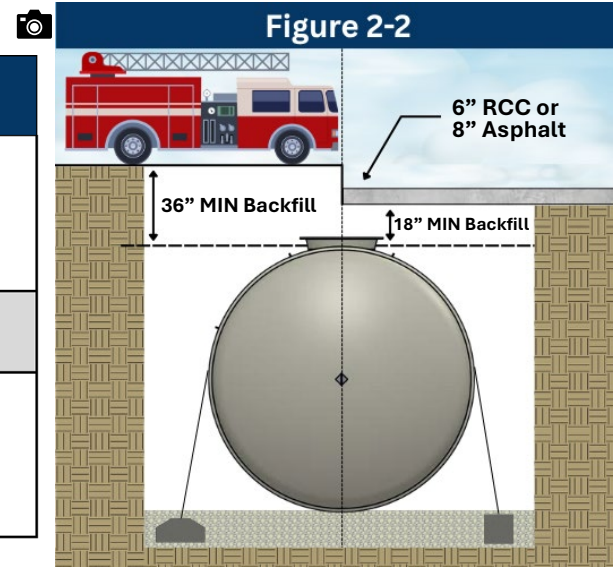

Note: Traffic loads are defined as AASHTO H-20 and HS-20 Loading

Note: The maximum burial depth for a standard tank is 7ft from top of tank to grade.

Note: The National Fire Code of Canada requires 39" of backfill in traffic areas if no concrete/asphalt is used.

Table 2-3: Tank Clearances Summary

Installation	Tank Clearances	
	A	B
Stable Soil	18"	18"
Unstable Soil	18"	1/2 Tank Diameter
Using Deadmen	2 x Deadmen Width (24" or 36")	18"
Shored Hole	18" or 2 x Deadmen Width	36"

Table 2-3

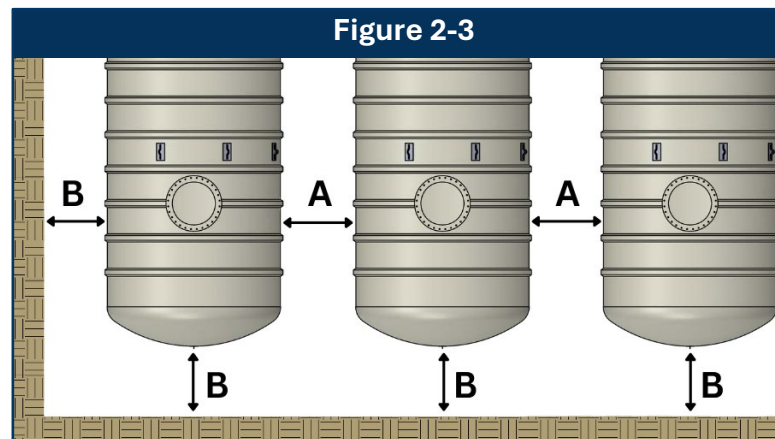

Note: Spacing between tanks placed end to end will follow the "B" spacing minimum value.

Note: All measurements to be from the outside diameter of the tank ribs.

Note: National Fire Code of Canada requires 24 in between a fuel tank and another tank or structure. (See Figure 2-3 "A")

Anchoring Tanks Considerations:

Note the tank clearances in Table 2-3 if using deadmen.

In wet conditions, sufficient overburden and/ or an appropriate anchoring system must be used to offset buoyancy of the tank. Minimum burial depth may not be sufficient to anchor the tank in buoyant conditions. Even with deadmen, for most anchoring systems, a tank is not adequately protected against flotation until the tank is fully backfilled and the top slab is in place. Contact FTS for assistance in sizing of anti-flotation systems for engineer to record review of approval.

KEY NOTIFICATIONS!

Important Notes:

The use of backfill material other than what is specified in the FTS IMOG will void the limited tank warranty and absolve FTS from any obligations under the warranty.

Using unauthorized backfill material may cause tank failure or damage.

DO NOT use sand as primary bedding or primary backfill material.

The FTS warranty requires the contractor to verify via "Delivery Receipts" or "pick ticket" to confirm that backfill meets specifications and note this information on the Installation Checklist.

Contact FTS for information on possible alternative material if the rounded stone or crushed stone is close to "Primary Backfill" requirements.

2.2. Bedding, Backfill and Geotextile Material Requirements

2.2.1. General Requirements

- Use clean, free-flowing material free of any dirt, debris, large rocks, organic material, ice, and snow. (referred to as backfill)
- Bedding is the (minimum) 12" of required material under the tank.
- Backfill is all material above that 12" of bedding and has the same specifications as the bedding material.
- For tanks with no traffic loads (H-20 and HS-20), as an option, you may use a combination of "Primary Backfill" and "Secondary Backfill" materials, after Primary Backfill has been brought to 50% of the tank diameter. This option is called a "Split Backfill" installation. See [Appendix C](#).
- For traffic loaded (H-20 and HS-20) tanks, "Split Backfill" is not allowed.
- For tanks buried deeper than 7ft to top of tank, "Split Backfill" cannot be used.

2.2.2. Primary Backfill

- See [Appendix B](#) for more information on Primary Backfill.
- Use coarse, rounded or crushed stones well-graded material, generally conforming to ASTM C33 sizes 6, 67, 7, or 8.
- No more than 5% of material should pass a #8 sieve.
- Rounded stone maximum size is 3/4".
- Crushed stone maximum size is 1/2".
- Avoid materials that degrade over time, such as soft limestone, shale, or shells.
- See **Figure 2-4** for a representative image of the size requirements for primary backfill materials.
- See **Table 2-4** for the FTS Gradation Requirements.



Figure 2-4

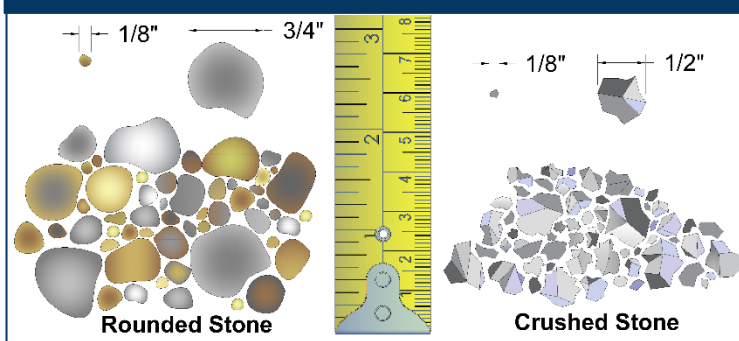

Sieve (Screen) Size	% Material Passing Screen Size	
	Rounded Stone	Crushed Stone
3/4 inch	90–100% (Max Size)	-
1/2 inch	10–100%	90–100% (Max Size)
3/8 inch	0–70%	40–100%
No. 4 (Approx. 0.2")	0–15%	0–30%
No. 8 (Approx. 0.1")	0–5% (Min Size)	0–5% (Min Size)

Table 2 - 4 – FTS Gradation Requirements

2.2.3. Secondary Backfill (for “Split Backfill” installations)

- Most installations use 100% Primary Backfill when installing tanks.
- Some projects may be eligible to use a combination of Primary Backfill with another material (“Secondary Backfill”).
- When a combination of Primary and Secondary Backfill is used, the installation is referred to as a “Split Backfill” Installation. Refer to **Figure 2-5** and [Appendix C](#) for more information.

2.2.4. Geotextile Fabric (“filter fabric”)

- Recommended to line the excavation in unstable soils or areas with fluctuating groundwater or silty in-situ soil.
- The tank owner/owner’s technical representative is responsible for determining the need for geotextile based on site conditions.
- Required in Split Backfill and unstable soil condition installations. (Refer to **Appendix C**)
- Do not use: Polyethylene film (tears/degrades easily).
- See **Table 2-5** for example geotextile specifications.
- If using geotextile, install before placing bedding material - shown below.
- In split backfill installations, place geotextile over primary backfill before adding secondary backfill. Ensure:
 - All joints overlap by at least 12 inches on tank and excavation hole.

Specification	Value	Test Method
Minimum Grab Tensile Strength	120 lbs	ASTM D4632
Maximum Apparent Opening Size	#50 US sieve (0.0117 in / 0.297 mm)	ASTM D4751
Minimum Flow Rate	18 gallons/min/ft ²	ASTM D4491
Minimum Permittivity	0.28 sec ⁻¹	ASTM D4491
Example Products	Mirafi 140NL, 140N, 160N, or equivalent	—

Table 2 - 5 – Example Geotextile Specifications

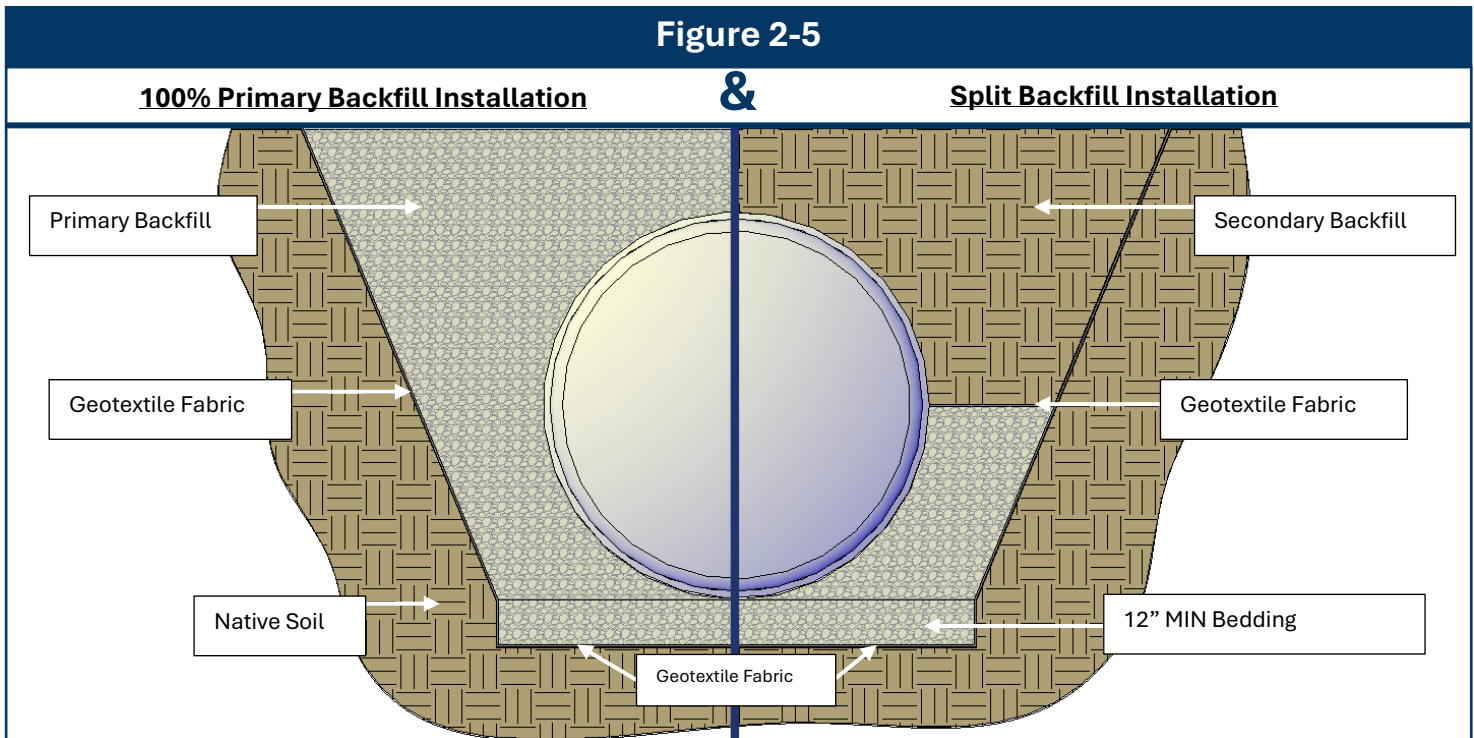

KEY NOTIFICATIONS!

Lifting and Handling Tanks

⚠ WARNING

Do not conduct preinstallation testing while the tank is on a trailer. Failure to follow this warning could result in death or serious injury.

Preparation:

Note: Large tanks may require a route survey.

Note: Be sure that all equipment used to lift the tank is rated to handle the load, reference the tank drawing, bill of lading, or the [APPENDIX A](#) at the end of the [IMOG](#) to determine the tank weight.

⚠ WARNING

Shipping Straps: Do not release the straps until lifting equipment (e.g., crane) is securely attached to the tank's lifting lugs, and all personnel are in a safe location.

⚠ WARNING

Lifting: Always secure the tank when moving, rotating, or lifting. Ignoring this warning could lead to death or serious injury.

Warning: Do NOT attempt to lift the tank with improper equipment (i.e. forklifts from underneath the tank.)

RESPONSIBILITY: Contractor is responsible for ensuring all lifting equipment is free from defect and/or damages

⚠ WARNING

Safety: Never stand under the tank while moving or lifting it. The contractor must ensure adequate site clearance and prep for truck trailer access.

Safety: Secure the tank to prevent rolling. Rotate slowly and carefully, as top-mounted accessories like manways can make the tank top-heavy and increase momentum.

2.3. Pre-Unloading Steps

- Inspect the tank for damage before unloading; contact FTS if damage is found.
- Sign shipping papers to accept delivery if no damage is found.
- Ensure lifting equipment can handle the tank's weight, reference the tank handling data [Appendix A](#)
- Clear a solid, level space for temporary aboveground placement after moving the tank from the delivery vehicle.

2.3.1. Unloading Instructions

- **Responsibility:** The contractor is responsible for unloading the tank.
- **Securing:** Never unstrap the tank until lifting equipment is fully attached.
- **Safety:** Stand clear during lifting and never stand under the tank.
- **Lifting:** Keep the lifting angle below 30 degrees or use a spreader bar as needed. See [Lifting Lug Summary](#)
- **Picking:** Tanks are shipped either upright or rotated to reduce height. Always lift the tank in its shipping position as it is on the truck:
 - Upright tanks: Lift tank off the truck in upright position.
 - Rotated tanks: Lift tank off the truck in rotated position.
- **Lifting Lugs:** Use the top lifting lugs; do not wrap chains or cables around the tank. Use guide ropes to assist but never lift with guide lugs.
- **General:** Do not drag, drop, or roll the tank.

2.3.2. Temporary Aboveground Placement

- Place the tank in its shipping position on the ground.
- Avoid water accumulation in freezing temperatures to protect the tank.
 - Example: Cover areas that pool water with plastic and duct tape.
- **Surface:** Ensure the tank is placed on a flat, obstruction-free surface.
- **Securing:** Always chock the tank with deadman, sandbags, or tires; tie down if high winds are expected. (deadman shown below)
- **UV Protection:** If stored above ground for an extended period (up to 12 months depending on location), ensure the tank is covered, tarped, or otherwise UV-protected.

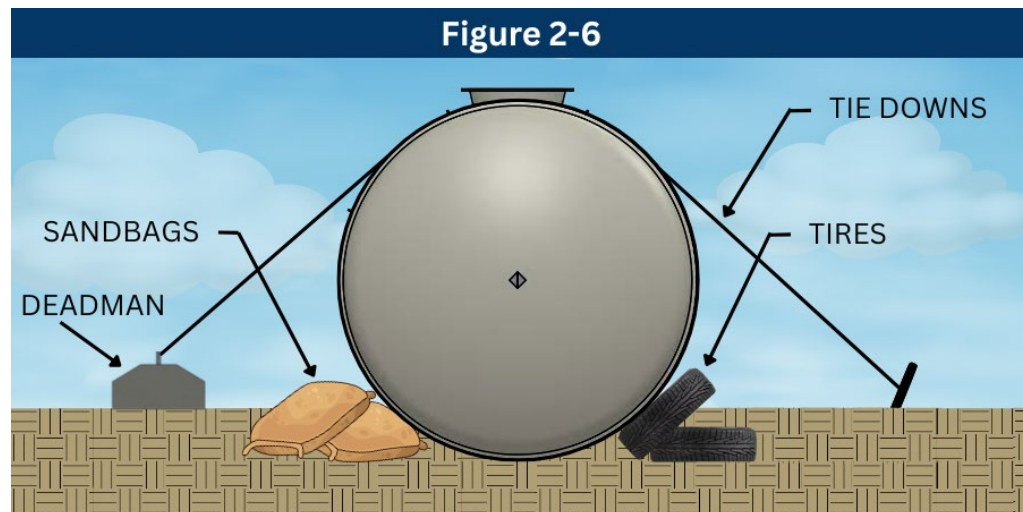

KEY NOTIFICATIONS!

NOTICE

Failure to provide sufficient overburden and/or an appropriate anchoring system could cause tank failure or could result in damage to the tank and/or surrounding property.

- Evaluate each site carefully for potential water table rise or trapped water—both during and after installation.
- Tanks are not fully protected from flotation until backfill is complete, and the top slab is in place.
- The FTS Anchoring System general engineered design (less than 25,000 gal tank) is for an empty tank, with the groundwater up to grade, one containment sump on the tank top, and a minimum 3 feet of backfill above the tank.
- Larger tanks or those with multiple sumps may require more backfill.
- Contact FTS for information on tank buoyancy calculations.
- **Tank Spacing:** May need to increase when using deadmen anchors, especially for side-by-side tanks (allow 24"–36" between tanks to fit deadmen). See **Table 2-3**.
- **Anchor Strap Placement:** Always position FTS anchor straps area of the tank with the marked arrows. ▶◀ (Examples on **Figure 2-7**.)

2.4 Anchoring Tanks

- When installing tanks, account for the possibility of the tank rising due to high groundwater if there is not enough overburden. To prevent this, an appropriate anchoring system may be required.

2.4.1. FTS supplies an Anchoring System that includes the following components as shown in Figure 2-7

- Fiberglass Anchor Straps ("hold-down straps")
- Galvanized Adjustable Anchor Points (supplied with deadman)
- Galvanized Turnbuckles
- Precast Concrete Deadmen

2.4.2. Anchor Straps

- Use only manufacturer-provided fiberglass straps.
- Strap locations are marked on the tank with arrow symbols (▶◀).
- Anchor point locations must also be adjusted to meet the ▶◀ locations.
- Attach strap ends to anchor points using supplied turnbuckles.
- FTS-supplied pultruded fiberglass straps are provided with galvanized D-ring connections.



Figure 2-7

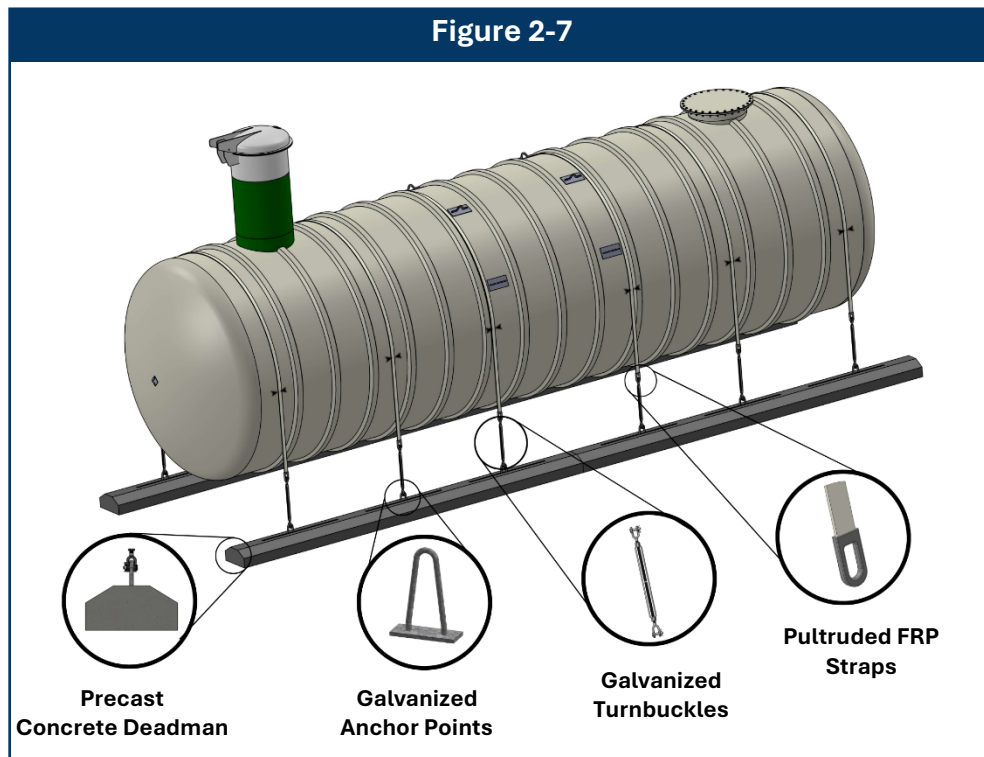

KEY NOTIFICATIONS!

▲ WARNING

Only use the anchor points when lifting and positioning the deadman. A spreader bar may be required to lift longer sections of deadman. Use guide ropes to guide the deadmen when lifting. Failure to do so could result in death or serious injury.

- Minimum tank spacing should be increased to fit deadman outside the tank shadow (see **Figure 3-1**).
- For deadman dimensions and further info, refer to **Table 2-3** or contact engineering support at engineering@fgtsolutions.com.

NOTE: Non-FTS supplied anchoring systems are the responsibility of the tank owner/owner's representative, .

- Ratchet straps are **NOT** acceptable methods for strapping tanks to deadman.
- Wire rope **CANNOT** be used in place of the FTS-supplied hold down strap.

For **non-FTS supplied** anchoring systems, additional components may be used, such as:

- Contractor-supplied turnbuckles.
- Custom anchor points (not supplied by FTS).
- Cast-in-place concrete deadman or anchor slab.
- Note: There is no substitute for FTS supplied hold down straps.

2.4.3. Hardware & Anchor Points

- The tank owner/owner's representative is responsible for providing proper hardware if not using the manufacturers anchoring system.
- Hardware must meet industry standards and be corrosion-protected (coated/galvanized). FTS-supplied galvanized hardware meets that standard.
- Locate anchor points per **Figure 2-7**. Align within ±1 inch per **Table 3-2**.

2.4.4. Turnbuckles

- Used to connect deadman anchor points to FRP anchor straps.
- Turnbuckles must be a minimum 3/4" diameter.

2.4.5. Deadman

- Deadman are reinforced concrete beams designed per the ACI Code.
- FTS-supplied deadman are shipped in sections of various lengths.
- The overall length typically matches the tank length and is shown on FTS project submittal drawings.
- Dimensions for FTS-Supplied Deadman:

Tank Diameter	Deadman Size (W × H)
4 ft, 6 ft, 8 ft	12" × 12"
10 ft, 12 ft	18" × 8.75"

- Placement:
 - Sections must be placed end-to-end on both sides of the tank.
 - Use equal number and proper spacing on both sides.
 - Refer to **Section 3.1** for information regarding the steps of deadman placement during the installation.
- ▲ Do not place the deadman under the tank "shadow", see **Figure 3-1**.
- Excavation Placement: **See Figure 3-2**.



Tank Diameter	Placement	Notes
4 ft, 6 ft	At base of excavation (in bedding)	Not allowed on top of bedding
8 ft, 10 ft, 12 ft	On top of bedding material	10 ft and 12 ft deadman may be placed at base

2.4.6. Anchor Slabs

The tank owner is responsible for the design of anchor slabs.

- The total length of the slab must be at least the same as the length of the tank, with a minimum thickness of 8 inches.
- The width of the slab is determined by the tank diameter, and it must extend at least 18 inches beyond each side of the tank, except for 4-foot-diameter tanks, where the minimum extension is 12 inches.
- Each anchor strap must have a separate anchor point, and all anchor points must be engineered to withstand the buoyancy forces of the tank.
- The number and location of anchor straps supplied by the contractor must match marked positions per the FTS drawings. (▶◀)
- Excavations must allow for 12 inches of backfill between the bottom of the tank and the bottom of the excavation or the top of the anchor slab.

KEY NOTIFICATIONS!

NOTICE

Do not fill a tank with fuel or water for ballasting prior to reading these instructions. Failure to follow these instructions could result in damage to property.

⚠ WARNING

Inert the tank and use inert gases (not air) to pressure test a tank that contains or has contained flammable or combustible liquids or vapors. Failure to follow this warning could result in an explosion and could result in death or serious injury.

⚠ WARNING

If flammable or combustible product is used as ballast, exercise special care in handling. Safeguard against sparks, fire or product spills. Failure to follow this warning could result in a fire or an explosion and could result in death or serious injury.

⚠ WARNING

The tank must be adequately vented to prevent the development of vacuum or pressure when filling or emptying the tank. Failure to properly vent the tank could cause tank failure and could result in death or serious injury.

NOTICE

If a tank is configured in such a way that one part of the tank could be full of ballast while other part(s) of the tank could be empty (such as multicompartiment fuel tanks and baffled water tanks), ballast should be added evenly between each tank compartments/chambers.

2.5 Ballasting Tanks (Adding Liquid)

- The ballast level in the tank must either be lower than the backfill material or less than 12 inches above the water level in the hole, see **Figure 2-8**.
- Only under wet-hole conditions should ballast be added before the backfill is 75% of the way up the tank. See the “Backfilling and Installing Tanks” **Section 3.1**. for more information on installing tanks in wet-holes.

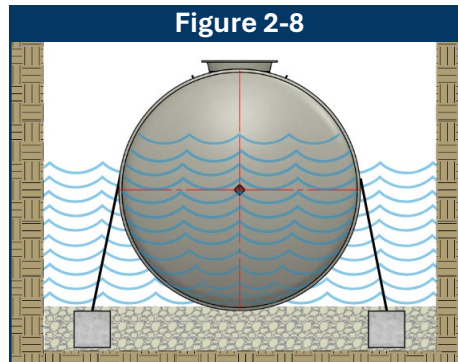

Figure 2-8: NOTE

Liquid in tank must not be more than 12 inches higher than water in excavation hole during installation

- For most anchoring systems, a tank is not adequately protected against flotation until the tank is fully backfilled and the top slab is in place.
- Regardless of the historical water table, during the installation process, the tank should be ballasted completely after the backfill is at least 75% of the way up the tank and after post-installation testing has been successfully completed.

2.5.1. Pressure Testing and Ballasting

- If the tank is going to be pressure tested, typically, tanks should be pressure tested before ballasting.
- Do not use atmospheric air when testing pressure-testable tanks that have held flammable or combustible product.
- Use nitrogen or other inert gas when testing these fuel storage tanks.
- If the tank is ballasted with water, the tank can be pressurized for pressure testing normally (maximum 5psig for 10' diameter **OR** 3psig for 12' diameter).

NOTE: When pressure testing a tank that is ballasted, depending on the ballast level in the tank, the remaining space in the tank can pressurize rapidly.

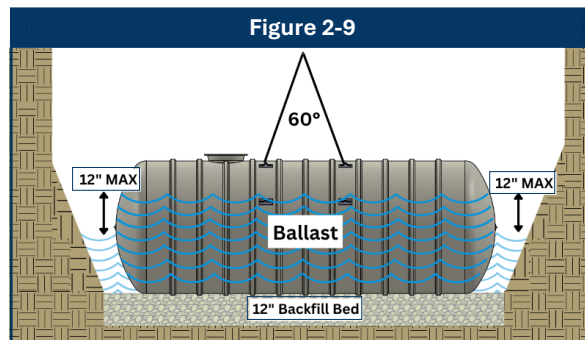

- Care must be taken so that the use of ballast does not contaminate the product being stored. **NOTE:** This is especially important for potable water, chemical and diesel exhaust fluid (DEF) tanks.
- Contamination can be avoided by doing one of the following:
 - Ballast the tank with a liquid compatible with the product being stored.
 - Clean the tank after ballasting to eliminate any contaminating product.

Measurement Steps!

Over deflection of the tank can cause the tank shell to buckle and result in a complete tank failure.

Figure 2-10

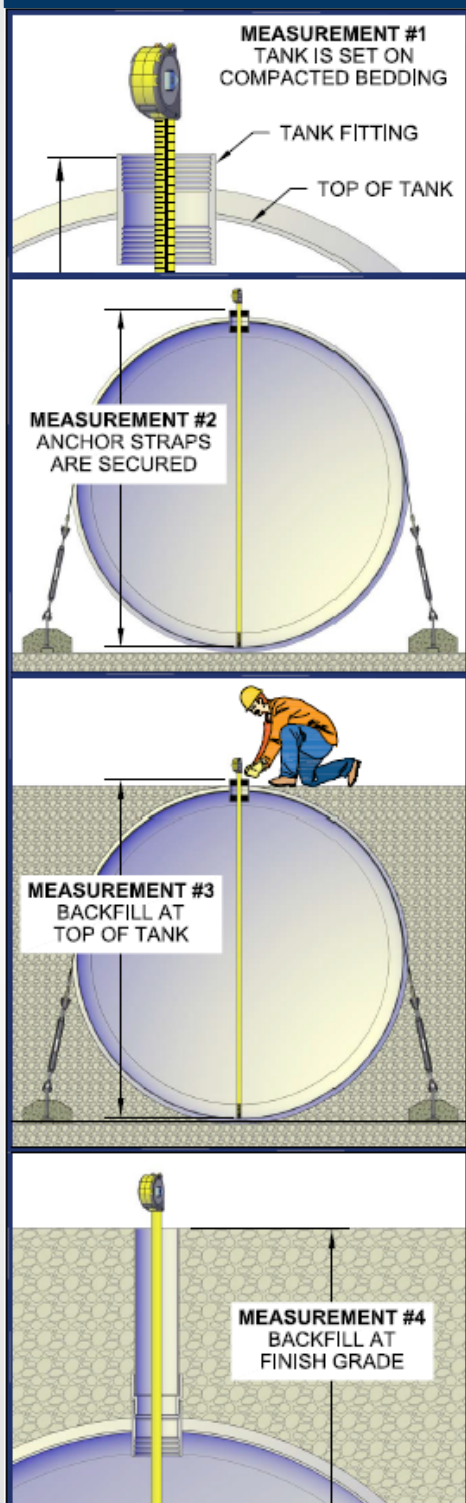

2.6. Deflection Measurements

2.6.1. Prior to installing the tank and throughout the installation process, deflection measurements must be recorded and recorded on the [FTS Checklist](#).

2.6.2. Deflection measurements can be taken by either inserting a dipstick or tape measure inside the same service fitting every time and measuring the distance from the bottom of the tank to that service fitting.

2.6.3. Four measurements must be recorded throughout the install process during the following stages of installation: **Figure 2-10**

- Measurement #1: Set on compacted backfill
- Measurement #2: After anchor straps are secured
- Measurement #3: Once backfill is flush with the top of the tank
- Measurement #4: When backfilling is complete and at subgrade*

***Note:** Measurement #4 could include the length of a standpipe. Subtract that standpipe length if necessary.

2.6.4. Measurement #1 is to be used as a control in which all other deflection measurements are compared to. To calculate deflection, subtract Measurement #2 from Measurement #1 and record it in the Installation Checklist*.

***Note:** subtract Measurement #3 from Measurement #1 and record it in the Installation Checklist*.

***Note:** subtract Measurement #4 from Measurement #1 and record it in the Installation Checklist*.

2.6.5. At any time throughout the installation process, deflection measurements can be taken by measuring from the bottom of the tank to the top of the service fitting and subtracting it from Measurement #1. Must use the same service fitting for all other deflection measurements.

2.6.6. Calculated deflection measurements are to be compared to the allowable deflection listed in **Table 2-10**. It indicates that the tank is not properly installed if deflection exceeds the allowable deflection limit.

Tank Diameter	Allowable Deflection
4ft	1/2"
6ft	3/4"
8ft	1 1/8"
10ft	1 1/2"
12ft	1 3/4"

Table 2-10



AS RECEIVED REQUIREMENTS

Side Section of FTS-IMOG

AS RECEIVED REQUIREMENTS FOR DOUBLE-WALL TANKS

For dry-monitored tanks, all tanks must arrive at the jobsite with at least:

- 10 inches of mercury on the interstitial space
- 7 days of vacuum held on the interstitial space (as indicated by the shipping papers).

For brine-monitored tanks, all tanks must arrive at the jobsite in the following condition:

- No visible brine on the outside or inside surfaces of the tank.
- The brine reservoir must have brine in it (normally approximately half-full).

NOTE: If the “As Received” section requirements are not met, proceed to the “Troubleshooting” **Section 2.7** of FTS-IMOG.

NOTE: Photo documentation is required showing that the tank has meets the tank “As Received” requirements and must be provided to FTS along with the completed FTS Checklist as part of any the tank warranty claim. The form must be signed/initialed by the tank owner/owner’s representative as having met the requirements, as applicable.

Figure 2-11: Testing Manifold

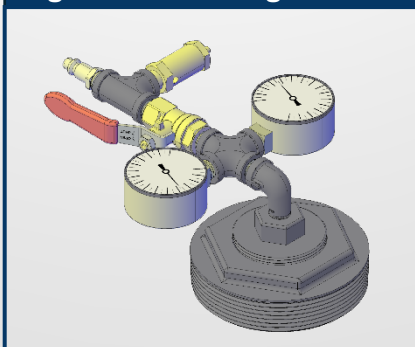

Or [Click here](#) for the FTS Webpage:

2.7. Tank Testing Requirements

2.7.1 All Tanks Require:

- Visual inspection at the time of delivery, noting any damage during shipment or other anomaly (for example, deep scrapes on the tank, loss of vacuum interstitial gauge reading, monitoring fluid visible outside of the tank reservoir or no fluid in reservoir).

NOTE: If shipping damage has been detected, contact FTS.

- Four Tank Deflection measurements are required throughout the installation and recorded on the installation checklist. A complete copy of the complete FTS Checklist is required as part of the warranty requirements. Refer to the tank warranty for more information on warranty effectiveness. See **Section 2.6** for more information regarding taking the required tank deflection measurements.
- Photo documentation is required throughout the installation process as noted in **Section 3.1**. The installer is required to verify that photos have been taken during tank installation as noted on the complete FTS Checklist. Refer to the tank Warranty for more information on warranty effectiveness.
- Some Tanks may use an Optional Hydrostatic Test for water/wastewater tanks not equipped for pressure testing. This test may be requested by the tank owner/owner’s representative if pressure testing is not possible. See **Section 2.7.2**
- Fuel tanks may use Onsite Pressure Testing: FTS designates this as an optional test, subject to the tank meeting the shipping requirements. May be required by regulators and/or if the “As Received” requirements are not met for double-wall tanks. See **Section 2.8**

2.7.2. Optional Hydrostatic Testing Procedure

- Normally used for tanks other than fuel tanks.
 - This optional test can be used for water or wastewater tanks that are not pressure-testable due to the accessories on the tank.
- NOTE:** Follow all instructions in **Section 2.5**. (“Ballasting Tanks”) when adding liquid to the tank.
- Use the following procedure for the optional Hydrostatic test:
 - Seal off the influent and effluent piping, and any fittings that are below the tank top with watertight caps or plugs.
 - Fill the tank with water to a level that is 3 inches [7.6 cm] into the access openings after the backfill is at least 75% of the way up the tank.
 - Let the water stand in the tank for a minimum of 1 hour (or longer if required by applicable local codes).
 - Allow sufficient time so that the water temperature stabilizes.
 - If the water level drops, check to see that plugs or caps sealing off the piping are tight. Then add more water to fill air voids and return the water level back to the standard testing level.
 - Let the water stand in the tank for a minimum of 1 hour.
 - If the water level does not stabilize, contact FTS.

KEY NOTIFICATIONS!

NOTE: Some brine-monitored tanks may require the addition of brine to the reservoir at this stage of the installation, or during the hydrostatic monitoring system set-up. FTS ships 5 extra gallons of brine with all brine-monitored tanks.

NOTE: Brine can be made onsite using *Dowflake*, a dry calcium chloride that dissolves easily in water. To make brine, mix about 5 pounds of *Dowflake* per gallon of water until fully dissolved. You can add food coloring to help distinguish it from other fluids.

Brine Recipe:

- 5 lbs Dowflake per gallon of water
- Optional: add food coloring for identification

2.8 Troubleshooting Double-Wall Tanks

2.8.1. Before calling FTS, if the “As Received” requirements are not met, consider the following:

2.8.2. Troubleshooting Dry Tanks

Issue	Action	Note
Vacuum gauge unresponsive or stuck	Tap lightly with finger	Helps reseal gauge needle
Fitting threads appear loose or leaking	Hand-tighten the fitting	Loose fittings can cause vacuum loss
After completing above steps	Contact FTS	After completing above steps

2.8.3. Troubleshooting Brine Tanks

- If the tank does not appear otherwise damaged during shipment, and the “As Received” requirements are not met, the tank may still be acceptable for service. However, some additional troubleshooting is needed to help eliminate non-damage-related shipping issues.
- The brine is dyed to differentiate it from other fluids, such as fuel or water, and any point, even if the tank is ballasted or in service, brine should be visible in the fluid in the tank.
- When brine tanks are shipped, the tanks are agitated by road conditions and. Agitating the tank can affect the brine level in the interstice by “freeing” small amounts of trapped air in the interstice (causing the brine level to fall in the reservoir).
- Rising groundwater levels, backfill compaction, ballasting, and temperature increases can also cause fluctuations in the brine level.
- If brine is visible on the **INSIDE** of the tank, call FTS.
- If brine is visible on the **OUTSIDE** of the tank, there is a possibility that brine from the reservoir has splashed onto the tank exterior during shipment (the reservoirs are shipped vented).
 - If brine is visible on the outside of the tank, wipe the area dry and wait for the reformation of brine over a period of at least one hour. If the brine reappears, call FTS.
- If the brine reservoir does not have brine in it, call FTS.

FTS Pre-Construction Checklist

This section ends the planning and pre-construction activities that should be completed prior to the actual installation of the tank(s). Use this checklist as a quick reference to make sure all key planning steps are covered before you move on to installation.

	Task	Reference
<input type="checkbox"/>	Installer has read the entire IMOG; owner will receive IMOG, completed FTS Checklist & photos	Intro 1.0
<input type="checkbox"/>	Regulatory approvals/permits secured; all codes reviewed with authorities	Intro 1.0
<input type="checkbox"/>	Site-specific safety plan in place (OSHA excavation, PPE, barricades, vapor & water control)	1.4 / 2.1
<input type="checkbox"/>	All tools on Section 1.4 list on-site (excavator, crane, tampers, test manifold, air/inert gas, etc.)	1.4
<input type="checkbox"/>	Lifting gear rated for tank weight; lay-down area leveled & accessible	2.3
<input type="checkbox"/>	Utilities located; soil report reviewed; groundwater elevation noted	2.0
<input type="checkbox"/>	Excavation sized for at least 12 in bedding and required clearances	2.1
<input type="checkbox"/>	Burial depth & cover verified for traffic/non-traffic; ≤7 ft unless custom	2.1
<input type="checkbox"/>	Primary backfill ordered (ASTM C33 sizes 6/67/7/8) & delivery tickets retained	2.2
<input type="checkbox"/>	Decision on split-backfill; geotextile fabric meeting spec available	2.2
<input type="checkbox"/>	Floatation risk evaluated; burial depth, deadmen, or anchor slab designed & sized	2.4
<input type="checkbox"/>	FRP straps, ¾ in turnbuckles, anchor points & 12 in bedding above slab confirmed. Confirm deadmen on the bedding or at the excavation bottom	2.4
<input type="checkbox"/>	Clean water source & disposal arranged; ballast plan meets IMOG limits	2.5
<input type="checkbox"/>	Pressure-test manifold/inert gas available if required	2.7
<input type="checkbox"/>	Tools ready for four deflection measurements; recorded on checklist	2.6
<input type="checkbox"/>	Photo-documentation sequence mapped per Installation Checklist	2.7 / 3.1
<input type="checkbox"/>	Route survey complete; crane/truck arrival & stockpile areas scheduled	2.0
<input type="checkbox"/>	Storm-water diversion & de-watering equipment arranged	2.1
<input type="checkbox"/>	FTS Checklist printed with spaces for contractor & owner's rep initials/date	Checklist

KEY NOTIFICATIONS!



NOTICE

It is the contractor's responsibility to have a safe and stable access to get a truck, trailer, or tank to the excavated hole. **NOT** the responsibility of FTS.

Per the requirements of [FTS Installation Checklist](#) take photos of the tank being lifted off the trailer.

Lifting Lugs are only designed to support the weight of an empty tank. Do not attempt to lift a tank containing liquid.

It is **SOLEY** the contractor's responsibility to secure lifting equipment to the tank, **NOT** the delivery driver .

Lifting Lug Summary

Read Before Unloading or Setting Tanks

Tanks in the Upright Position		
These tanks have either 2 or 4 total lifting lugs		
End view of a tank in the upright position	Always pick a tank with 2 lifting lugs if there are 2 total lifting lugs	Always pick a tank with 4 lifting lugs if there are 4 total lifting lugs

Tanks in the Rotated Position		
These tanks have either 3 or 6 total lifting lugs		
End view of a tank in the rotated position	Always pick a tank with 2 lifting lugs if there are 3 total lifting lugs	Always pick a tank with 4 lifting lugs if there are 6 total lifting lugs

⚠ Lifting Slings Warnings

⚠ WARNINGS:

- ▲ Always inspect the lifting slings for damage before use.
- ▲ Never use a damaged sling. No field repairs are available for damaged lifting slings - contact FTS immediately if damage is found.
- ▲ Ensure the lifting equipment is properly sized for the tank.
- ▲ Don't twist, knot, snag or tie slings together. Avoid jerking or swinging the load. Keep slings away from sharp edges.
- ▲ Follow all standard rigging procedures when connecting to the lifting slings.

FTS Lifting Sling Features

Safety Benefits:

- Ground-level hookup, no ladders, no men on tank, one man lift.

Setup:

- Two pre-fitted polyester web slings (Type 4, twisted eyes), rated for the tank weight, pre-positioned on "Lift Here" markings on the tank.



- No spreader bar needed.
- Attached slings directly to the hook on the lifting equipment.

Handling:

- Lift the tank off the truck in the position it was shipped in.
- If necessary, place the tank on ground, re-choke to rotate the tank vertically and set in the excavation.
- Slings are single-use and buried with the tank.

PROCEDURE FOR LIFTING FTS TANKS WITH SLINGS

- ▲ **WARNING** Non-compliance voids the warranty and risks injury, damage, or tank failure. Read all instructions, supplemental documents, visuals, and guidelines before installation.

1. General Information

- ASME B30.9-rated polyester web lifting slings are supplied with the tank & designed for its weight.
- Follow all applicable safety regulations and industry best practices.
- Always secure tank before moving; never stand beneath or near a suspended tank.
- Tanks must be lifted and set only - never rolled, dragged, or dropped.
- Do not rotate the tank while lifting from the trailer.
- For additional installation requirements, consult the [FTS Installation Manual](#) or contact FTS Sales.

2. Lifting FTS Tanks with Slings

- Use the provided lifting slings - minimum two per tank:
 - Slings are placed by FTS on the flat areas between ribs at locations marked "LIFT HERE."
- Confirm slings are secure, balanced, and with a maximum of 60 degrees between the slings. FTS places the slings at locations that do not exceed 60 degrees.
- Do not rotate tank while suspended.

FTS Tank Dia	Sling Length	Sling Spec
4-ft	19'	3" 1-Ply
6-ft	27'	3" 1-Ply
8-ft	34'	3" 2-Ply
10-ft	42'	3" 4-Ply
12-ft	50'	6" 4-Ply

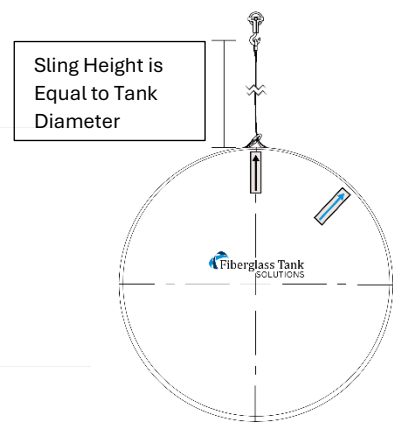

Unloading Sequence:

1. Confirm slings are in correct marked positions.
2. Release the sling ends attached to the trailer.
3. Lower crane hook, attach sling to hook.
4. Slowly lift to equalize sling tension.
5. Raise tank clear of trailer and set down temporarily or directly into the excavation (if the tank was not shipped rotated).
6. If needed, adjust the choke position using dome-end markings as a guide (Ⓜ) for tank rotation and final setting.
7. When ready, lift and carefully set the tank into the excavation.
8. Secure tank, lower crane, unhook slings. Slings can be buried with the tank.
9. Repeat steps 1-9 for any additional tank(s).

First Steps:



Release the slings attached to the trailer deck.



Ensure straps are in proper lifting location
(Example Only: marked "LIFT HERE" on tank flats)



Lower crane hook to the now loose ends of slings. Secure the loose ends to crane hook.

Second Steps:



Once secured, carefully position crane boom where slings loads are equal



Choke hitch must be pulled tight before the lift. NOT pulled down during the lift.



Slowly raise crane hook ensuring choke hitch is over centerline of tank

Third Steps: Rotated Tanks



Lift tank off trailer and set on smooth surface – free of obstructions, maintaining a maximum of 60 degrees between slings.

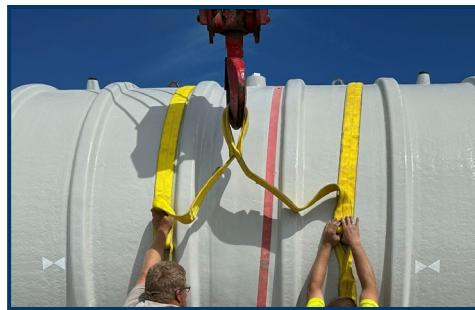

When Rotated: Reposition slings according to tank lift/set locations to rotate tank upright.



Lift tank into set location, lower crane to unhook & drop slings, then continue with the installation of the tank.

Please Note: Most 10' and 12' tanks arrive to the jobsite in the rotated position and need the optional process in the "Third Steps" section of this document. This allows for those rotated tanks to be set and re-picked with the same straps and slightly moving the choke position so that the tank can be lifted in the upright position in the excavation.

KEY NOTIFICATIONS!

NOTE: If mechanical compaction is required, all backfill is to be compacted with hand-guided, vibrating-plate, mechanical compactors when within 8 feet of the tank

NOTE: Install any non-tank-top centerline pipe connections throughout the backfill process as needed.

[Website Link to Pre-Cast Concrete Deadman Cutsheets](#)

3.1. Installing Tanks

3.1.1. Steps in a Dry-Hole Installation (no water in the excavation)

- Level out the bottom of the excavation using primary backfill to fill in any low spots as needed.
NOTE: If using geotextile, line the excavation hole with geotextile filter fabric and place geotextile on top of the native excavation.
- Set the deadmen in hole so that they are below the tank within the bedding. For 8-foot diameter tanks, the deadmen must be placed on top of the 12" of bedding. Allow for adequate spacing between the deadmen so the deadmen do not fall within the shadow of the tank. See **Figure 3-1. Photo documentation required for this step & must be included in checklist.**
- The tank must be centered between the deadmen.
- Create a smooth level bed of approved primary backfill material that is a minimum of 12 inches thick. Bedding must be compacted to 85% density proctor and recorded in the Installation Checklist. Some crushed stone may require mechanical compaction on the bedding.
- Mount any bottom sumps/fitting to the tank at this time, if applicable.
- Set the tank on the bedding and **record Deflection Measurement #1** at this time.
- Install the hold down straps and turnbuckles per **Figure 3-1 & 3-2 and Table 3-2.**
- Strap locations are marked by arrowhead vinyl stickers on the tank shell and on the custom tank submittal drawings. Align the adjustable galvanized anchor points in the deadmen with the strap locations. ▶◀
- All straps and turnbuckles should be uniformly tightened so that they are snug on the tank but not overly tightened to the point that they cause the tank to deflect.
- Record Deflection Measurement #2** at this time.

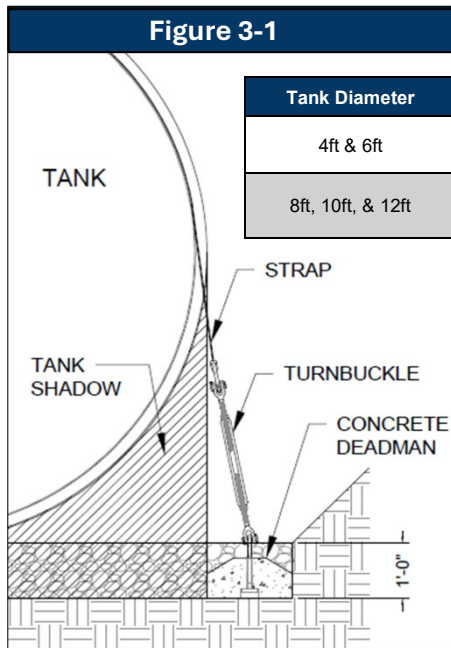

Tank Diameter	Placement	Notes
4ft & 6ft	At base of excavation (in bedding)	Not allowed on the top of bedding
8ft, 10ft, & 12ft	On the top of bedding material	10ft & 12ft deadman may be place at the base

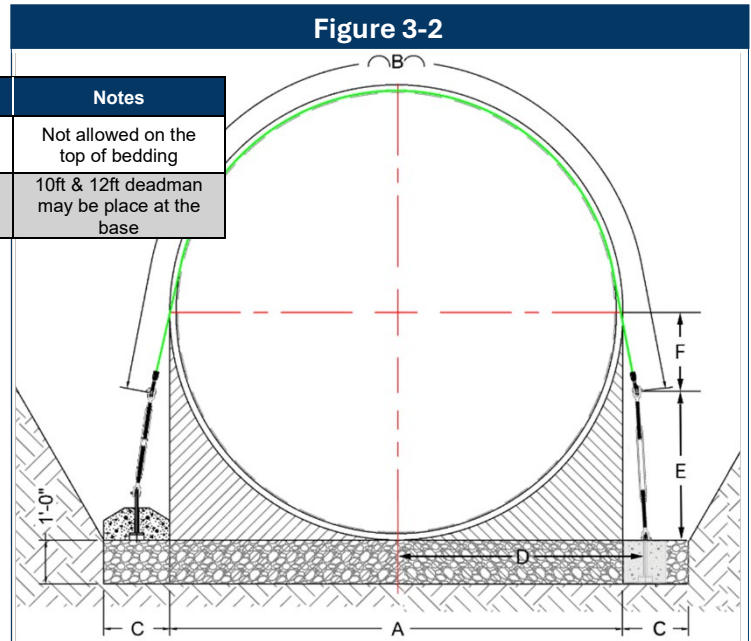

Tank Diameter	"A" (Tank OD)	"B" (Strap Length)	"C" (Deadmen Width)	"D" (Center of Deadman Placement)	"E" (Turnbuckle Dimension)
4'	4' - 4"	85"	12"	2' - 8"	1' - 10"
6'	6' - 4"	145"	12"	3' - 8"	2' - 0"
8'	8' - 4"	181"	12"	4' - 8"	3' - 1"
10'	10' - 4"	236"	18"	5' - 11"	3' - 4"
12'	12' - 9"	300"	18"	7' - 1"	3' - 5"

Table 3-2 – Deadman Anchoring Dimensions Chart

KEY NOTIFICATIONS!

Failure to follow the warnings below could result in damage to the tank, property damage, serious personal injury, and/or death.

The use of rammer-type compactors over the top of the tank is not permitted.

The water level in the tank should never exceed the elevation of the backfill material or never exceed the water level in the excavation hole by more than 12 inches.

It should be noted that for many anti-floatation systems that the tank is not fully safe guarded from the buoyant forces of groundwater until backfill has been installed all the way to grade or subgrade.

The tank must be vented to atmospheric pressure throughout the ballasting process.

If applicable, it is important to thoroughly clean and dry the inside of the tank post installation and after the ballast water has been removed. This is especially pertinent for potable water, diesel exhaust fluid, and chemical storage tanks to prevent contamination.

Tamping rod – non metallic, typically PVC.

Refer to the **Section 2.1 Summary** for minimum bury depth requirements.

3.1.2. Steps for Backfilling the Tank

1. Place 12 inches of backfill around the tank. Carefully hand tamp the backfill underneath the dome ends and between ribs to remove all voids.
2. Approved primary backfill must be installed in 12-inch lifts or less. Alternate the 12-inch lifts on each side of the tank during the installation process so as to not create more than a 12-inch difference in backfill elevation on either side of the tank. See **Figure 3-3**.
3. Angled sheeting and hand shovels are recommended for crushed stone.
4. Tamping rods are recommended for free-flowing round pea gravel.
5. Install a 2nd 12-inch lift by repeating steps 1 and 2 of **section 3.1.2**.
6. Following the installation and compaction of the 2nd backfill lift, begin the process of bringing the backfill to the top of tank.
7. Once backfill has been installed to the top of the tank, **record Deflection Measurement #3**.
8. Complete all tank-top piping, riser and/or containment installation at this time.
9. Proceed with backfilling to finish grade, or subgrade (if a concrete/asphalt top slab is required). **Record Deflection Measurement #4** at this time.
10. Install the reinforced or unreinforced concrete/asphalt top slab at grade if applicable. Refer to the **Section 2.1** for minimum bury depth requirements. The FTS Checklist should be completed at this time.

3.1.3. Steps for Wet Hole Installations (water in the excavation)

1. For wet-hole installations, follow the same procedures outlined in “**Section 3.1.1. Dry-Hole Installation**” with the additional procedures outlined in this section.
2. Utilizing pumps, dewater the hole prior to installation. Continue removing water from the excavation throughout the installation process. At no point should the water level exceed the backfill elevation.
3. Proceed with Steps 1 through 5 of **Section 3.1.1**.
4. Partially ballast the tank with water so that it settles firmly onto the compacted bedding. Allow for adequate venting before and during ballasting.
5. Proceed with Steps 6 and 7 of **Section 3.1.1**.
6. Proceed with Steps 1 through 8 of **Section 3.1.2** above. Continue to ballast the tank with water throughout these steps. The water level in the tank should never exceed the elevation of the backfill material or never exceed the water level in the excavation hole by more than 12 inches.

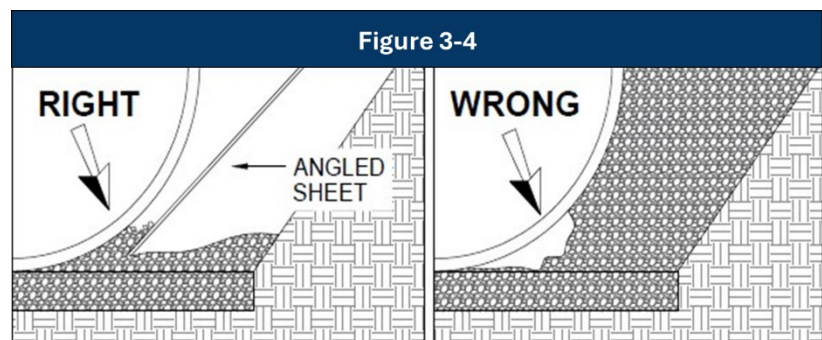
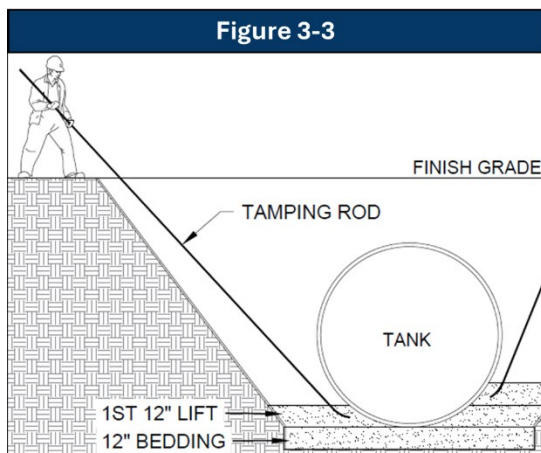

KEY NOTIFICATIONS!

▲ WARNING

All underground tanks must be properly vented to prevent pressure or vacuum buildup during filling or emptying. Improper venting can cause tank failure and lead to serious injury or death.

▲ WARNING

Vent-restriction devices for overflow should not be installed if owner/operator will allow pump or pressure filling of tank. Failure to follow this warning could cause tank failure, and could result in death or serious injury.

NOTICE

All wet monitoring systems must be vented for proper operation. Failure to do this could result in damage to the tank and/or surrounding property.

NOTICE

All internal piping must be at least 4 inches from the tank bottom. Failure to follow this notice could result in damage to the tank and/or surrounding property.

NOTICE

All metal fittings and other metal components must be coated to protect against corrosion. Failure to do this could result in damage to these parts, the tank and/or surrounding property.

3.2. Venting Tanks

3.2.1. Primary Tank Venting

- The primary tank is designed to operate at atmospheric pressure, requiring a properly sized venting system to maintain this condition during filling and emptying.
- When installing overflow protection, such as alarms, automatic shut-off devices (e.g., fill pipe flapper valves), or vent-restriction devices (e.g., ball-float valves), follow the manufacturer's instructions and consult the authority having jurisdiction to determine the appropriate activation level.
- Be aware that some jurisdictions prohibit ball-float valves, so it is essential to review applicable codes and regulations.
- Typically, a dedicated tank vent should have a cross-sectional area that is at least half the area of the larger of the inlet or outlet pipes.
 - To calculate the cross-sectional area of a pipe, use the formula:
Area = π × (diameter ÷ 2)². Or Area = 3.14 × (diameter ÷ 2)²

3.2.2. Venting Interstitial Spaces

- If the tank's interstitial space contains monitoring fluid, it can be vented by drilling a 1/4-inch hole in the standpipe cap or side. If high groundwater is a concern, install a vent line above the water level. If the space is dry, venting is not needed. (See **Figure 3-5** in **Section 3.5**)

3.3. Piping

3.3.1. Internal Piping

- All piping must conform to all applicable codes and standards.
- For tanks with manways or access openings, refer to the table and relevant figure in the Piping and Tank **Internal Diameter Sidebar below** to determine the appropriate internal piping length.

3.3.2. External Piping

▲ WARNING

The tank must be isolated from all piping when the external piping is being pressure tested. The test pressures for external piping could cause tank failure, and could result in death or serious injury.

- When extending monitoring or vapor-recovery piping to the surface, use at-grade fittings that differ from fill fittings and cannot connect to standard fill hoses.
- All connections to the tank must be flexible. Provisions must be made to accommodate movement and misalignment between the piping and the tank. Failure to do this could result in damage to the tank and/or surrounding property.

Letter	Definition		4 ft	6 ft	8 ft	10 ft	12 ft
A	Internal diameter of single-wall (SW) and double-wall (DW) tanks.	SW	48"	72"	96"	120"	144"
		DW	48"	72"	96"	120"	144"
B	Top of service fitting → tank bottom (SW/DW)	SW	49 1/3"	73 3/8"	97 3/8"	121 3/8"	145 3/8"
		DW	49 3/4"	73 3/4"	97 3/4"	121 3/4"	145 3/4"
C	Top of service fitting on a manway cover → tank bottom (SW/DW)	SW	55 7/8"	79 7/8"	103 7/8"	127 7/8"	151 7/8"
		DW	56 1/4"	80 1/4"	104 1/4"	128 1/4"	152 1/4"
D	Top of an access opening → tank bottom (SW)	SW	56 3/8"	80 3/8"	104 3/8"	128 3/8"	152 3/8"
E	Top of internal flange on an access opening → tank bottom (SW)	SW	42 3/8"	66 3/8"	90 3/8"	114 3/8"	138 3/8"

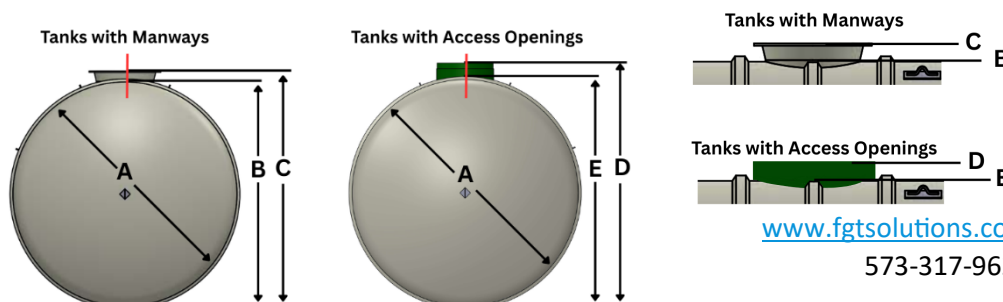

KEY NOTIFICATIONS!

⚠ WARNING

NOTE: In freezing conditions, protect collar channels, access riser open channel, and sump from water accumulation. Freezing water may cause damage.

3.4. Containment Collars

NOTE: In freezing conditions, protect collar channels, access riser open channel, and sump from water accumulation. Freezing water may cause damage.

- Single and double-wall containment collars are factory installed to the tank top to provide a means of secondarily containing leaks from pumps and piping.
- Containment Sumps are designed to provide a watertight connection to the tank collar utilizing an adhesive joint or fiberglass kit.
- FTS does not build Containment Sumps, follow the manufacturer's specific installation instructions for the Containment Sump that is being installed.

3.4.1. Collar Test Instructions

- Before sump assembly, it is best practice to first leak test the containment collar(s).
- To perform the test:
 1. Secure a measuring stick with 1/16-inch increments in the sump.
 2. Fill the collar with water to the highest point and wait 15 minutes.
 3. Record the liquid level.
 4. Wait at least 1 hour, then re-measure.
 5. A level change over 1/8 inch may indicate a leak.
 6. Visually inspect the collar connection to tank wall and adhesive channel joint for leaks.

NOTE: Test liquids must be disposed of properly.

Example Figure

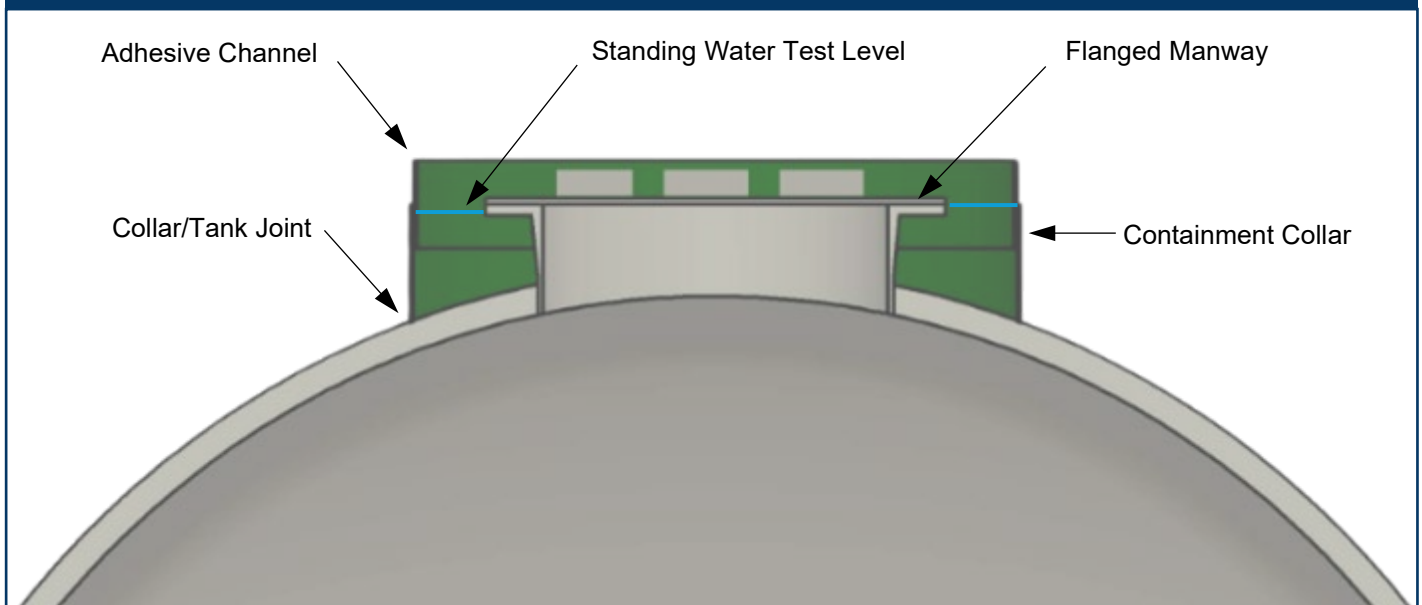

3.5. Interstitial Monitoring of Double-Wall Tanks

3.5.1. General Overview

- Double-wall tanks have a space between the inner and outer walls for leak detection.
- Each tank includes at least one access fitting to monitor this space.
- Dry and wet interstitial tanks use access fittings; wet types connect to a reservoir.
- Sensors (liquid/vapor) are installed through this fitting:
 - Typically after backfilling
 - For easier installation, insert the sensor before installing the monitoring riser pipe.

3.5.2. Monitoring a Dry Interstitial Space

- Use electronic or mechanical sensors to detect leaks and water.
- Place the sensor at the lowest point in the space:
 - Use a drawstring if needed
 - If tank is sloped, use the low end
- Access fittings are sealed or vented independently of the primary tank

3.5.3. Monitoring a Wet Interstitial Space

- Space is usually factory-filled with monitoring fluid.
- Some tanks ship with extra fluid for top-offs.
- Do not add fluid until after burial and system setup.

CAUTION:

**All wet interstitial spaces must be vented.
Unvented tanks may be damaged.**

3.5.4. Checking and Maintaining the Monitoring Fluid

- Record fluid level on shipping paperwork and installation checklist.
- Required reservoir level: ½ full.
 - Only add fluid post-installation.
 - If reservoir is empty, contact FTS.
- Use only nonmetallic standpipes in access fittings.
 - Fluid levels may shift during shipping or setup.
 - Place reservoir on high end if tank is sloped

3.5.5. Monitoring Fluid Level Changes During Installation

- The fluid level may naturally rise due to:
 - Pressure testing
 - Rising groundwater levels
 - Backfill compaction
 - Ballasting
 - Temperature increases
 - Product level changes
- Monitor and record the fluid level throughout installation and record in the FTS Checklist as required.

3.5.6. Setting the Monitoring Fluid Level (Wet Tanks)

3.5.6.1. After Backfilling and Installing the Top Slab:

- Check and adjust the monitoring fluid level in the reservoir.
- NOTE:** Incorrect fluid levels can cause false alarms.

3.5.6.2. Establishing the Proper Fluid Level:

- Follow the monitoring probe manufacturer's instructions to determine the initial fluid level.

3.5.6.3. Probe Placement Guidelines:

- Keep the probe upright and in contact with the top of the tank.
- **For a two-sensor probe:** Set the brine level midway between the sensors.
- **For other probes:** Use 7 inches from the top of the tank as the starting point.
- Adjust the fluid level based on the product level:
 - ¼ to ½ full: Fluid level at the starting point.
 - Empty to ¼ full: Fluid level **1 inch below** the starting point.
 - ¾ full to full: Fluid level **1 inch above** the starting point.
- Add or remove brine as needed to maintain the correct level.

Figure 3 - 5

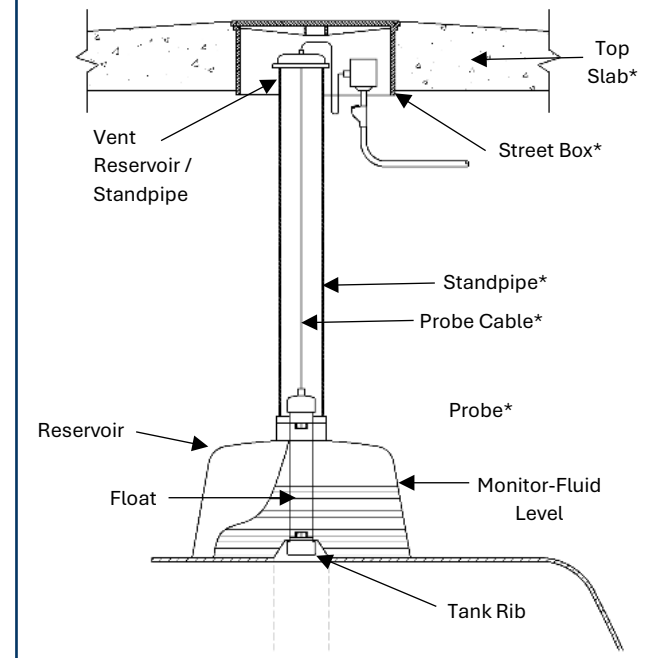

KEY NOTIFICATIONS!

▲ WARNING
Improper entry can cause fire, explosion, or asphyxiation, leading to serious injury or death.

▲ WARNING
Over-pressurizing can cause tank failure, leading to serious injury or death.

▲ WARNING
If a tank lacks overflow protection, the vent must be unrestricted and at least the same size as the fill line. Failure to do so can be dangerous.

▲ WARNING
Pump or pressure filling is not recommended as it may cause overflow or over-pressurization, even if vented properly. This can result in tank failure, serious injury, or death.



3.6. Tank Entry (Confined Spaces)

3.6.1. Entering Tanks

- Tanks, containment sumps, manway extensions and access risers are confined spaces.
- No one should ever enter a tank unless:
 - It is properly emptied and vented.
 - AND They are trained in confined-space entry and follow all OSHA, federal, state and municipal regulations.

3.7. Filling Tanks

- NEVER overfill the tank.
- If using a pump or pressure filling, the owner/operator must take precautions to prevent over-pressurization.

3.7.1. Filling Fuel Tanks

- Before each fill, the tank owner/operator must:
 - Ensure the tank is properly vented See **Section 3.2.**
 - Check for overflow protection (e.g., automatic shut-off or ball-float valve), which reduces tank capacity.
 - Notify the delivery service if the tank has overflow protection.
 - Determine the tank’s reduced capacity before filling.
 - Follow manufacturer/installer guidelines to calculate how much additional product the tank can hold.
- If the tank has a ball-float valve, it should be gravity-filled only.
- Ensure the fill line and drop tube are properly grounded to prevent static discharge.
- Control the initial fill rate to minimize product sloshing.

KEY NOTIFICATIONS!

CAUTION: Always wear eye protection and gloves when handling, grinding, cutting, or attaching the sump unit to prevent injury.

▲ NOTICE:

- **Do not drop or roll** sump components, as they can be easily damaged. Secure all pieces in windy conditions.
- **Do not place heavy objects** on the sump top after installation. **The street box and concrete pad should not transfer weight to the tank**, as this can cause damage.

3.8. Installing Containment Sump & Access Risers

3.8.1. General Guidelines:

- Containment Sumps and Access Risers come in various models and sizes from different manufacturers.
- Always follow the manufacturer’s assembly instructions for your specific sump model.
- If the sump or riser will be FRP bonded to the tank, reference the “FTS Field FRP Bonding Instructions” installation supplement.
- For Access Risers, refer to the FTS installation supplement for “Installing Grommets and Conduit Fittings in Risers”
- Containment sumps and Access Risers can serve as:
 - Tank access
 - Access for maintenance of tank internals, such as filters in water/wastewater tanks.
 - Enclosures for submersible pumps and termination points for secondary piping.
 - Containment areas for leaks from pumps and piping connections.
 - Continuous monitoring zones using electronic sensors.

3.8.2. Before Installing a Containment Sump or Access Riser:

- Check local codes and regulations for compliance with monitoring requirements.
- Ensure the sump is not exposed to traffic loads.
- Inspect the sump for shipping damage.
 - Contact FTS if damage is found.
- Confirm the sump is the correct length for the burial depth.
- Obtain the specific installation instructions for the sump model.

3.8.3. Installing the Containment Sump: (See Figure 3-6 below)

- Backfill to the top of the sump system, keeping backfill away from the sump top
- Isolate the sump from traffic loads using a concrete form/barrier.
 - Allow at least 3 inches of clearance between any load-bearing structure and the sump top.
 - A plywood sheet or similar material can act as a barrier.
- Select a street box with enough clearance for easy cover operation.
- Set the street box and ensure proper access to remove the watertight cover.
- Continue backfilling to subgrade, ensuring proper drainage away from the sump access opening when installing the surface pad.

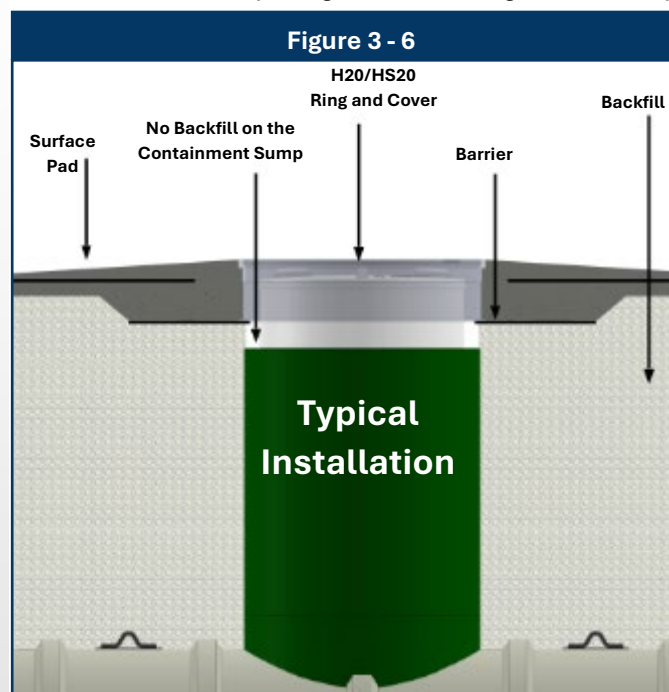

Glossary Term	Description
Access Opening	Non-flanged opening (24–36") for inspecting non-fuel tanks. Not watertight.
Anchor Slab	Reinforced concrete slab beneath tank bedding.
Baffle / Bulkhead	Internal divider in water/wastewater tanks. Called a bulkhead in fuel tanks.
Ballasting	Adding liquid to a tank.
Base Tank	Largest compartment in a multicompartment fuel tank.
Bedding	Minimum 12" of backfill material under the tank.
Containment Sump	Below-grade enclosure for tank and piping access.
Deadman	Reinforced concrete beams along the tank length for anchoring.
Double-Wall Tank	Tank with primary and secondary walls and a monitorable space between.
Dry Interstitial	No fluid in interstice at shipment.
Dry Monitor Fitting	Access point to dry interstitial space.
End Compartment/Tank	Smaller compartment(s) in a multicompartment fuel tank.
Flat	Surface area between exterior tank ribs.
In-Situ Soil	Native soil at the installation site.
Interstitial Space	Gap between tank walls for monitoring.
Guide Lug	Lug used to steer tank during lifting.
Lifting Lug	Lug used to lift the tank.
Manway	Flanged, watertight access opening (22–30") with bolted steel cover.
Monitor Fitting	Port for checking double-wall tank interstice.
Monitoring Fluid	Colored calcium chloride solution for hydrostatic monitoring.
Monitoring Reservoir	Expansion chamber on wet-monitored tanks.
Multicompartment Tank	Fuel tank with separate compartments.
Pressure-Relief Valve	Opens to release pressure at a set point.
Pressure Testing	Uses air/gas and soap to detect leaks.
Primary Backfill	Specified gravel/stone for bedding and cover.
Rib	Circumferential fiberglass reinforcement.
Riser	Pipe extending from access opening to grade.
Projection	Distance from tank wall to flange/pipe end (internal/external).
Secondary Backfill	Alternative granular backfill per spec.
Single-Wall Tank	Tank with one containment wall.
Test Manifold	Valve/fitting assembly for pressure testing.
Torque Rating	Max tightening torque (25 ft-lbs for fittings/manways). Tighten in star pattern (i.e.: tire)
Wet Interstitial	Interstitial shipped filled with brine for hydrostatic monitoring.

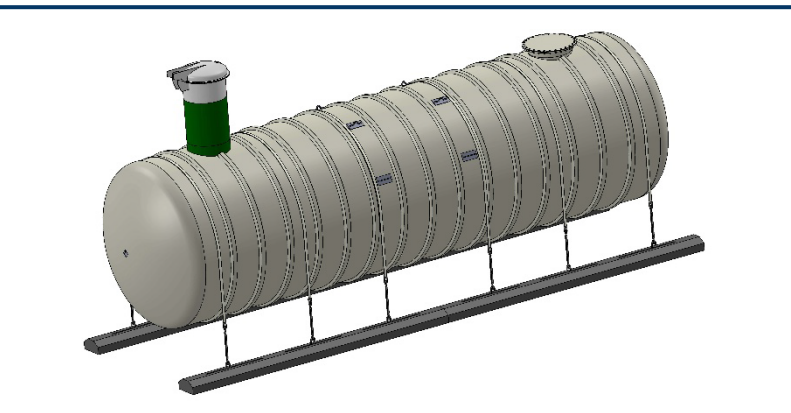
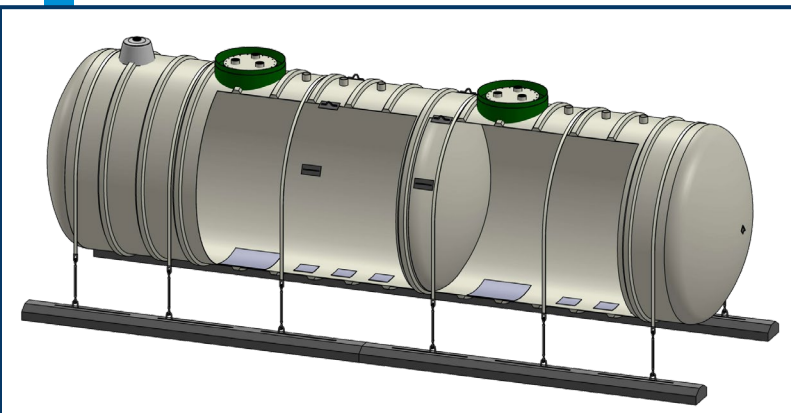



Information Chart Underground Storage Tanks

Tank Diameter	Nominal Capacity	Actual Capacity	St. Wall Length	Overall Length	SW Shell Weight	DW Shell Weight	Deadman			
							Straps	Quantity	Length	Weight of Single Deadman
(FT & IN)	(GAL)	(GAL)	(FT - IN)	(FT - IN)	(LBS)	(LBS)	(QTY)	(QTY)	(FT)	(LBS)
4 Ft. (48" ID) (52" OD)	600	610	5'-8"	7'-2"	400	700	2	2	12	1,800
	1,000	1,010	9'-11"	11'-5"	600	1,000	2	2	12	1,800
	1,500	1,542	15'-7"	17'-1"	800	1,400	2	2	16	2,400
	2,000	2,075	21'-3"	22'-8"	1,000	1,800	4	4	12	1,800
	2,500	2,608	26'-11"	28'-4"	1,300	2,200	4	2	12	1,800
								2	16	2,400
	3,000	3,007	31'-2"	32'-7"	1,400	2,500	4	4	16	2,400
	3,500	3,540	36'-10"	38'-3"	1,600	2,900	6	4	18	2,700
4,000	4,073	42'-6"	43'-11"	1,900	3,300	6	2	12	1,800	
							4	16	2,400	
6 Ft. (72" ID) (77" OD)	1,500	1,759	7'-1"	9'-2"	800	1,100	2	2	12	1,800
	2,000	2,012	7'-7"	10'-8"	1,000	1,200	2	2	12	1,800
	2,500	2,505	10'-2"	13'-0"	1,100	1,300	2	2	12	1,800
	3,000	3,034	12'-7"	15'-6"	1,300	1,400	2	2	16	2,400
	4,000	4,021	17'-4"	20'-2"	1,500	1,700	2	2	18	2,700
	5,000	5,055	22'-0"	24'-10"	1,800	2,000	4	4	12	1,800
	6,000	6,031	26'-10"	29'-8"	2,100	2,500	4	4	16	2,400
	7,000	7,018	31'-6"	34'-4"	2,400	2,900	4	4	18	2,700
	9,000	9,009	42'-6"	43'-9"	3,200	3,600	6	2	12	1,800
								4	16	2,400
	10,000	10,014	46'-9"	48'-6"	3,800	4,200	6	4	16	2,400
2								18	2,700	
8 Ft. (96" ID) (101" OD)	5,000	5,009	11'-1"	14'-9"	1,900	3,000	2	2	16	2,400
	6,000	6,012	13'-9"	17'-5"	2,100	3,300	2	2	18	2,700
	7,000	7,015	16'-8"	20'-5"	2,400	4,100	4	4	12	1,800
	8,000	8,017	19'-1"	22'-9"	2,700	4,400	4	4	12	1,800
	9,000	9,020	21'-9"	25'-5"	3,100	4,800	4	2	12	1,800
								2	16	2,400
	10,000	10,023	24'-4"	28'-0"	3,200	5,400	4	2	12	1,800
								2	16	2,400
	12,000	12,028	29'-9"	33'-5"	3,700	6,100	4	2	16	2,400
								2	18	2,700
	15,000	15,036	37'-9"	41'-5"	4,400	7,400	6	4	12	1,800
2								18	2,700	
20,000	20,053	51'-0"	53'-9"	5,800	10,400	8	4	12	1,800	
							4	16	2,400	



Information Chart
Underground Storage Tanks

Tank Diameter	Nominal Capacity	Actual Capacity	St. Wall Length	Overall Length	SW Shell Weight	DW Shell Weight	Deadman			
							Straps	Quantity	Length	Weight of Single Deadman
(FT & IN)	(GAL)	(GAL)	(FT / IN)	(FT / IN)	(LBS)	(LBS)	(QTY)	(QTY)	(FT)	(LBS)
10 Ft. (120" ID) (125" OD)	8,000	8,009	10'-10"	15'-6"	2,600	3,500	4	2	18	2,700
	10,000	10,016	14'-3"	18'-11"	3,000	4,000	4	2	22	3,000
	12,000	12,023	17'-8"	22'-4"	3,400	4,600	4	2	22	3,000
	15,000	15,157	23'	27'7"	4,200	5,600	4	4	14	1,900
	18,000	18,046	27'-11"	32'-7"	4,800	6,500	6	4	18	2,700
	20,000	20,053	31'-4"	36'-0"	5,200	7,100	6	4	18	2,700
	22,000	22,109	34'-9"	39'-5"	5,700	7,700	8	2	18	2,700
								2	22	3,000
	25,000	25,047	39'-10 1/2"	44'-5"	6,500	8,700	8	4	14	1,900
								2	18	2,700
	30,000	30,041	48'-5"	53'-1"	7,600	10,300	10	6	18	2,400
35,000	35,133	56'-11 1/2"	61'-7"	8,900	11,900	12	2	18	2,700	
							4	22	3,000	
40,000	40,126	65'-6"	70'-2"	9,900	13,500	14	8	18	2,700	
12 Ft. (144" ID) (154" OD)	20,000	20,140	19'-6"	26'-1"	8,900	11,800	8	4	14	1,900
	25,000	25,216	25'-6"	32'-1"	11,000	14,300	8	4	18	2,700
	30,000	30,292	31'-6"	38'-1"	12,800	16,600	10	2	18	2,700
								2	22	3,000
	35,000	35,368	37'-6"	44'-1"	14,300	18,600	12	4	22	3,000
	40,000	40,444	43'-6"	50'-1"	16,100	20,900	12	4	14	1,900
								2	22	3,000
	45,000	45,521	49'-6"	56'-1"	18,100	23,400	14	4	18	2,700
								2	22	3,000
	50,000	50,597	55'-6"	62'-1"	19,900	24,800	18	6	22	3,000
55,000	55,673	61'-6"	68'-1"	21,600	28,000	20	4	14	1,900	
							4	22	3,000	
60,000	60,749	67'-6"	74'-1"	23,400	30,300	20	4	18	2,700	
							4	22	3,000	



Information Chart Underground Fuel Storage Tanks

Tank Diameter	Nominal Capacity	Overall Outside Tank Diameter (rib-to-rib)	Overall Tank Length	Actual Capacity Full	Estimated Weights*		Deadmen			
					DW Dry Weights	DW Wet Weights	Straps	QTY	Length	Weight of a Single Deadman
(FT & IN)	(GAL)	(FT - IN)	(FT - IN)	(GAL)	(LBS)	(LBS)	(QTY)	(QTY)	(FT)	(LBS)
6 Ft. (72" ID) (77" OD)	2,000	6'-5"	10'-8"	2,012	1,800	1,900	2	2	12	1,800
	2,500	6'-5"	13'-0"	2,505	2,200	2,300	2	2	12	1,800
	3,000	6'-5"	15'-5"	3,034	2,600	2,700	2	2	16	2,400
	3,500	6'-5"	17'-9"	3,528	3,000	3,100	2	2	18	2,700
	4,000	6'-5"	20'-1"	4,021	3,300	3,400	2	2	18	2,700
	4,500	6'-5"	22'-5"	4,515	3,700	3,800	4	4	12	1,800
	5,000	6'-5"	24'-9"	5,008	4,200	4,300	4	4	12	1,800
	5,500	6'-5"	27'-1"	5,502	4,500	4,700	4	2	12	1,800
	6,000	6'-5"	29'-7"	6,031	4,900	5,000	4	2	16	2,400
8 Ft. (96" ID) (101" OD)	5,000	8'-5"	14'-9"	5,009	3,400	3,600	2	2	16	2,400
	6,000	8'-5"	17'-6"	6,012	4,000	4,200	2	2	18	2,700
	7,000	8'-5"	20'-5"	7,015	4,500	4,800	4	4	12	1,800
	8,000	8'-5"	22'-9"	8,017	5,100	5,400	4	4	12	1,800
	9,000	8'-5"	25'-6"	9,020	5,600	6,000	4	4	12	1,800
	10,000	8'-5"	28'-9"	10,023	6,200	6,600	4	2	12	1,800
	12,000	8'-5"	32'-9"	12,028	7,300	7,800	4	2	16	2,400
	15,000	8'-5"	40'-9"	15,036	9,000	9,600	6	2	18	2,700
	20,000	8'-5"	54'-9"	20,050	11,900	12,700	8	4	12	1,800
10 Ft. (120" ID) (125" OD)	8,000	10'-5"	15'-6"	8,099	4,400	4,700	4	2	18	2,400
	10,000	10'-5"	18'-11"	10,016	5,400	5,700	4	2	22	3,000
	12,000	10'-5"	22'-4"	12,023	6,300	6,700	4	2	22	3,000
	15,000	10'-5"	27'-8"	15,157	7,700	8,200	4	4	14	1,900
	18,000	10'-5"	32'-7"	18,046	9,000	9,500	6	4	18	2,400
	20,000	10'-5"	36'-0"	20,053	9,900	10,500	6	4	18	2,400
	22,000	10'-5"	39'-6"	22,109	10,800	11,500	8	2	18	2,400
	25,000	10'-5"	44'-6"	25,047	12,300	13,000	8	2	22	3,000
	30,000	10'-5"	53'-0"	30,041	14,500	15,400	10	4	14	1,900
	35,000	10'-5"	61'-7"	35,133	16,700	17,800	12	2	18	2,400
	40,000	10'-5"	70'-2"	40,126	19,200	20,400	14	4	22	3,000

For Multicompartment Tanks:

At this time, 6' tanks are single compartment only.

The overall tank length does not change for multicompartment tanks.

The minimum compartment size for a multicompartment tank is 5,000-gallons for 10' tanks, and 4,000-gallons for 8' tanks.

For 10-foot-diameter double-wall fuel tanks, add 1200 lbs for a two-compartment tanks' bulkhead.

For 8-foot-diameter double-wall fuel tanks, add 800 lbs for a two-compartment tanks' bulkhead.

Refer to the FTS website for the appropriate calibration charts to use for each compartment of multicompartment tanks.

IMPORTANT NOTIFICATIONS!

Primary Backfill material should not be all one size stone – the material must be various sizes of stone that fit within a maximum and minimum size specified in this document.

Sieve is another word for screen.

“Sieve report”, “sieve analysis” and “gradation report” are equivalent names that describe a report that shows the size distribution of a proposed material.

Table 1-1 shows acceptable particle sizes distribution that should match the report.

Suppliers should always provide a report of the material that they propose to supply.

FTS recommends that the material supplier provide written verification that the material that they supply meets the primary backfill requirements.

If the material supplier does not supply a material size distribution report, an independent lab can perform a sieve test (ASTM C136) to verify compliance.

For reference, the FTS backfill specifications are based on ASTM C33, size #6, 67, 7 and 8.

FTS Primary Backfill Requirements

1.0. General Guidelines

- 1.1. The backfill supporting an underground storage tank is vital for a proper installation.
- 1.2. Use rounded or crushed stone as specified in the Fiberglass Tank solutions (FTS) Installation Manual and in this document. Note the following:
 - Using non-specified material can result in voids and/or poor compaction.
 - Using non-specified material will void FTS’s obligations on any warranty claim.
 - The specified materials are a commonly available materials and are very similar to the requirements for concrete aggregate.
- 1.3. Backfill must be clean, free-flowing, well-graded material that is free of:
 - Dirt, sand, large rocks
 - Organic material, roots, debris
 - Ice, snow, or anything frozen
- 1.4. The material must be hard and stable when wet or under load.
- 1.5. Avoid soft materials like soft limestone, sandstone, sea shells, and shale, which break down over time.

2.0. Primary Backfill Materials

- 2.1. Use coarse aggregate (rounded or crushed stone) meeting FTS size requirements. Refer to Figure 1-1 and Table 1-1.
- 2.2. For rounded stone: Use rounded particles sized from 1/8" to 3/4". It's often called "pea gravel," "pea stone," or "roofing gravel," depending on the region.
- 2.3. For crushed stone, use angular crushed particles sized from 1/8" to 1/2".

Sieve (Screen) Size	% Material Passing Screen Size	
	Rounded Stone	Crushed Stone
3/4 inch	90–100% (Max Size)	0
1/2 inch	10–100%	90–100% (Max Size)
3/8 inch	0–70%	40–100%
No. 4 (Approx. 0.2")	0–15%	0–30%
No. 8 (Approx. 0.1")	0–5% (Min Size)	0–5% (Min Size)

Appendix Table – FTS Sieve Report

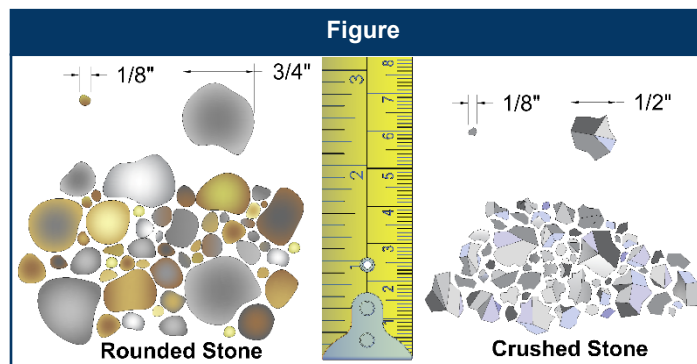

Split Backfill Requirements!

Do:
Obtain approval from the tank owner/regulators before using.
Use clean native soil, coarse sand, gravel or other acceptable materials as shown in this as secondary backfill.
Ensure 100% of material passes through a 1-inch sieve.
Compact the secondary backfill to at least 85% Proctor density.
Use geotextile ("filter fabric") to separate primary and secondary backfill (see Table 4 for the specification)
Install in 12–24-inch layers, compatible with compaction equipment.
Address potential frost heave issues.
Documentation required – type of geotextile, native backfill type, pictures must be noted on the Installation Checklist.
Do Not:
Do not this procedure in traffic areas (H-20/HS-20).
Do not use in deep burial installations (more than 7 ft).
Do not use clay as secondary backfill.
Do not use frozen material or material with roots, large rocks, debris, ice, or snow.

Split Backfill Installations

1.0. Introduction

- 1.1. Most installations use 100% Primary Backfill when installing tanks.
- 1.2. Some projects may be eligible to use less than 100% Primary Backfill (as described in the Installation Manual and Operating Guidelines) with another material ("Secondary Backfill").
- 1.3. These installations are referred to as "Split Backfill" Installations. Refer to the "Do" and "Do Not" tables on the left side of this document before proceeding.
- 1.4. In Split Backfill Installations, after Primary Backfill has been brought to 50% of the tank diameter, the diagram below illustrates how Secondary Backfill may be utilized:

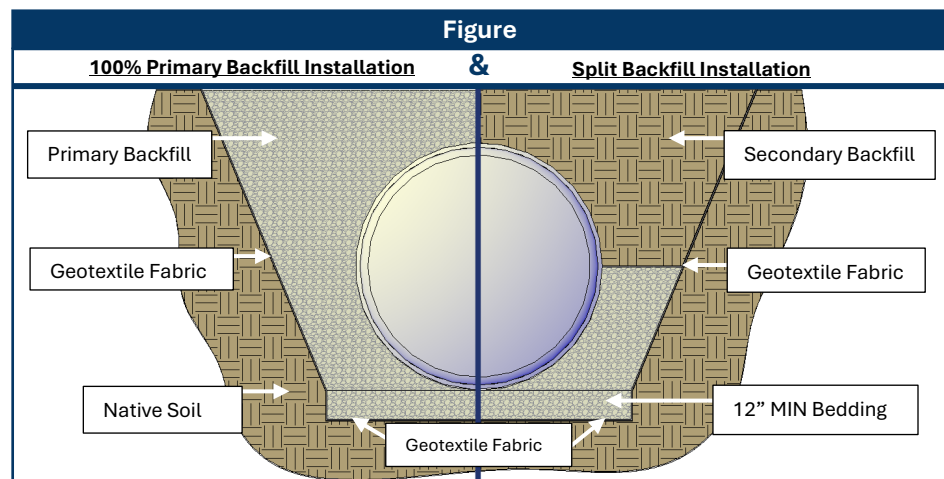

2.0. Secondary Backfill Materials

- 2.1. Typical Secondary Backfill materials are clean native soil, coarse sand, or gravel.
- 2.2. Other acceptable materials may be used as secondary backfill but may require different levels of compaction. This document defines those materials using terminology from ASTM D2487—the standard for classifying soils under the Unified Soil Classification System (USCS). Most loose (unconsolidated) materials can be identified using USCS symbols, which are two-letter codes. For example, "**GW**" stands for **well-graded gravel**. When soil mixtures are involved, a hyphen is used—for instance, "**GW-GM**" indicates **well-graded gravel with silt**.
- 2.3. Refer to Tables 1, 2 and 3 for information regarding USCS materials and compaction requirements for other acceptable materials that may be used as Secondary Backfill.

3.0 Installation

- 3.1. Use the specified Primary Backfill Material as the backfill vertically up to a point of 50% of the tank diameter. (See FIGURE 1-1.)
- 3.2. Follow the instructions in the Installation Manual on the placement of Primary Backfill.
- 3.3. In split backfill installations, place geotextile over primary backfill before adding Secondary Backfill, and ensure that joints overlap by at least 12 inches.
- 3.4. Install all Secondary Backfill in 12–24-inch layers, ensuring compatibility with compaction equipment.
- 3.5. If this procedure is used, record the type of geotextile, native backfill type, on the Installation Checklist, and take and save photos during installation.

Tables and Charts

First Letter	Definition	Second Letter	Definition
G	Gravel	P	Poorly Graded (uniform particle sizes)
S	Sand	W	Well Graded (diversified particle sizes)
M	Silt	H	High Plasticity
C	Clay	L	Low Plasticity
O	Organic		

TABLE 1 - USCS Symbols for Secondary Backfill and Bedding Materials

Compactive Effort	Definition	Proctor Density (In-Place)	Relative Density
Dumped	No compaction effort (self-compacting)	At least 85%	At least 40%
Slight	Some compactive effort required	At least 85%	At least 40%
Moderate	Additional compactive effort required	85% – 95%	40% – 70%
High	High level of compactive effort	At least 95%	At least 70%

TABLE 2 – Compactive Effort and Density Requirements for Secondary Backfill Materials

Material	Description	Compaction Requirement
Crushed Stone / Round Stone	Standard material (per FTS Backfill guidelines)	Dumped
GW, GP, SW, SP	Coarse-grained soils with < 12% fines	Slight
CL, ML, ML-CL (≥25% coarse)	Fine-grained soils (LL < 50), medium to no plasticity, ≥25% coarse particles	Moderate
GM, GP, SW, SP	Coarse-grained soils with fines	Moderate
CL, ML, ML-CL (<25% coarse)	Fine-grained soils (LL < 50), medium to no plasticity, <25% coarse particles	High

TABLE 3 – Acceptable Secondary Backfill Materials & Compaction Requirement

Specification	Value	Test Method
Minimum Grab Tensile Strength	120 lbs	ASTM D4632
Maximum Apparent Opening Size	#50 US sieve (0.0117 in / 0.297 mm)	ASTM D4751
Minimum Flow Rate	18 gallons/min/ft ²	ASTM D4491
Minimum Permittivity	0.28 sec ⁻¹	ASTM D4491
Example Products	Mirafi 140NL, 140N, 160N, or equivalent	—

TABLE 4 – FTS Geotextile Specifications

UST Installation Checklist

- Upon taking delivery of your structure, and before unloading, please review the BOL and packing slip included in the driver's packet and verify that all items are intact and present. It is encouraged to start a photo record of these items and continue through the entire installation process till completion.
- Fill out the installation checklist and return a copy, along with all pertinent pictures and supporting documents to the project owner.
- Checklist required for warranty claim. Failure to properly document the installation of your Fiberglass Tank Solutions product, will possibly void any warranty, direct or implied, to your structure.

Site Owner Info:

Owners Name _____ Installation Date: _____

Unit Serial Number(s) _____

Jobsite Street Address _____
Street: _____
City: _____ State: _____ Zip: _____

Installing Contractor Info: (Please Print)

Installers Name (Please Print) _____

Company Name _____

Company Street Address _____
Street: _____
City: _____ State: _____ Zip: _____

IMPORTANT STEPS!

Tank Deflection Measurements

Tank #1	Tank #2	Tank #3	Tank #4
---------	---------	---------	---------

1. Record Tank **Deflection Measurement #1** (Tank Set on Compacted Backfill)
2. Record Tank **Deflection Measurement #2** (After Installing Anchor Straps)
(Subtract Measurement #2 from Measurement #1 and record)
3. Record Tank **Deflection Measurement #3** (After Backfill is Flush with Top of Tank)
(Subtract Measurement #3 from Measurement #1 and record)
4. Record Tank **Deflection Measurement #4** (After Backfill is at Finished Grade)
(Subtract Measurement #4 from Measurement #1 and record)

_____	_____	_____	_____
_____	_____	_____	_____
_____	_____	_____	_____
_____	_____	_____	_____

Post-Installation

Tank #1	Tank #2	Tank #3	Tank #4
---------	---------	---------	---------

1. **Pressure/VAC** (DOUBLE WALL only) is completed according to IMOG and is documented for warranty
2. **Hydrostatic Test:** (if applicable) is completed according to IMOG and is documented for warranty
3. **Wet Monitoring-Fluid Tanks:** (if applicable)
 - A. Set the level of the monitoring fluid after backfilling and top-slab placement is completed.
 - B. Check and record monitoring-fluid level in the reservoir. (depth in inches)
 - C. Check for monitoring fluid inside tank
4. **Dry Monitoring sensor Tanks:** Locate pull string in monitor rib.
 - A. Carefully pull the sensor until it's located at the bottom of the tank. Leave pull string attached and inside of the riser pipe
5. **Secondary Containment Sump Test:** Add water to the containment sump assembly to check for leaks.
6. **Installation Manual:** Deliver Installation Manual and Operating Guidelines with the completed Checklist AND all photo documentation to the owner.

_____	_____	_____	_____
_____	_____	_____	_____
_____	_____	_____	_____
_____	_____	_____	_____
_____	_____	_____	_____
_____	_____	_____	_____
_____	_____	_____	_____
_____	_____	_____	_____

