

NOTES:

- PRESSURE GAUGES MUST HAVE A MAXIMUM FULL-SCALE READING OF 15 PSIG WITH GRADUATIONS IN 1/2 PSIG INCREMENTS.
- PRESSURE RELIEF VALVE TO BE SET AT 5 PSIG (MINIMUM); 6 PSIG (MAXIMUM).
- ITEMS ON THIS DRAWING ARE **LINKED TO EXAMPLE PARTS AVAILABLE FROM MCMASTER-CARR.**

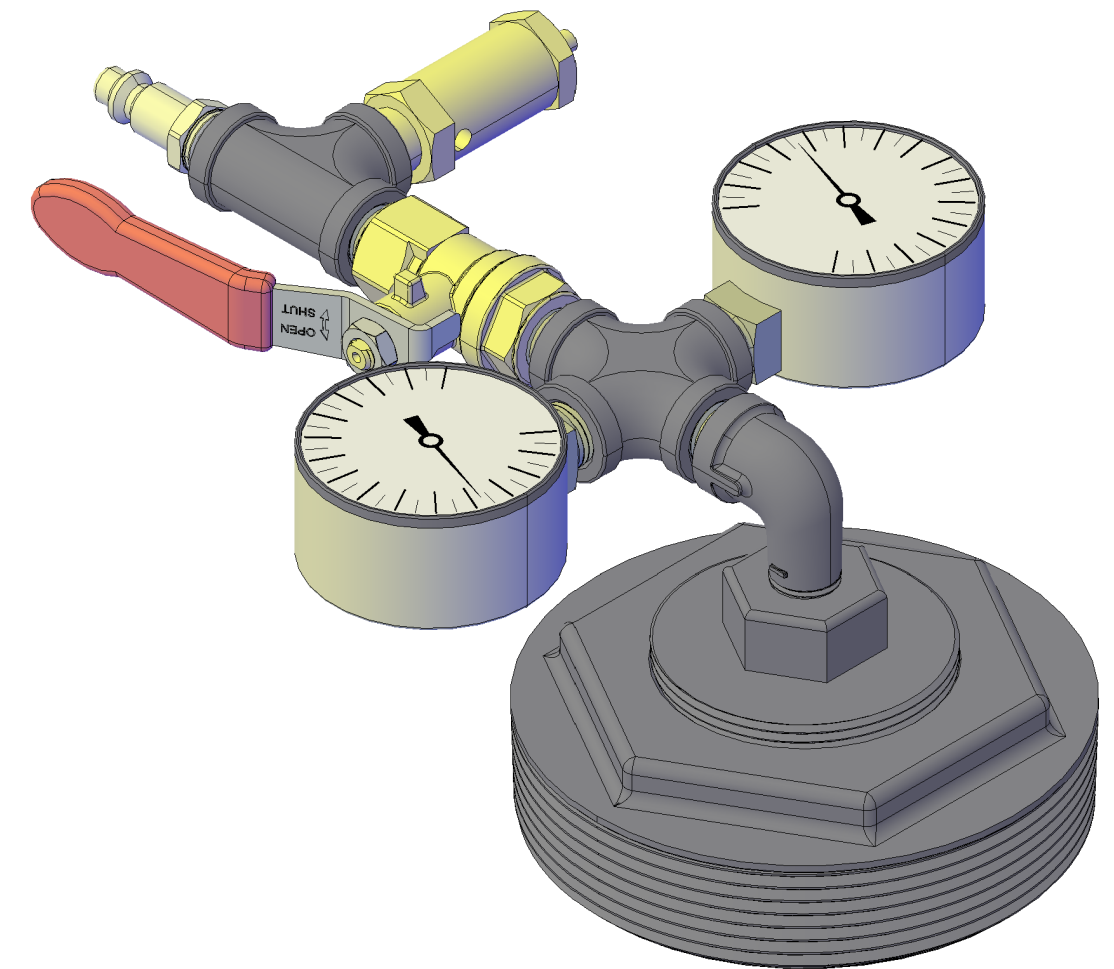

FTS - SUPPLIED TEST MANIFOLD